

# Installation manual Washer-extractors

WB6 70- WB6 90 – WB6 110

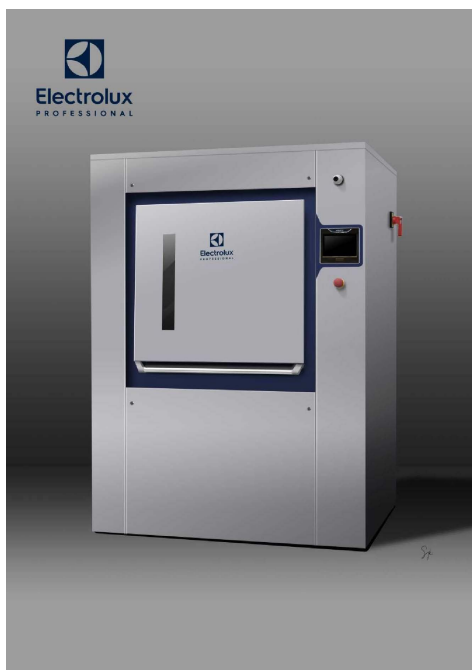

**Electrolux**  
PROFESSIONAL



# Contents

---

## Contents

1	Safety precautions.....	5
1.1	Symbols.....	11
1.2	Personal protection equipment.....	12
1.3	Preliminary instructions.....	12
1.4	Data plate explanation.....	14
1.5	Warranty terms and exclusions.....	17
2	Environmental information.....	19
3	Locking and tagging procedure.....	20
4	Handling.....	21
4.1	Lifting with a fork-lift truck.....	21
4.2	Lifting with handlings straps.....	21
5	Packing-Weight.....	22
5.1	Packing.....	22
5.2	Weight.....	23
6	Technical characteristics.....	23
6.1	Explanation of following installation drawings.....	23
6.2	Washer extractor type WB6 70.....	24
6.3	Connections WB6 70 :.....	27
6.4	Washer extractor type WB6 90.....	30
6.5	Connections WB6 90 :.....	33
6.6	Washer extractor type WB6 110.....	36
6.7	Connections WB6 110 :.....	39
7	Sound levels.....	41
8	Working place lighting.....	42
9	Supplies.....	42
10	Mechanical installation.....	43
10.1	Unpacking.....	43
10.2	Installation.....	43
10.3	Installing the shock absorber plates.....	43
10.4	Instructions for securing the machine on the ground.....	44
10.5	Setting the shock apsorber plates.....	46
11	Remove of the transport locks fitted.....	46
12	Barrier partition.....	47
13	Drain connection.....	49
14	Waters connections.....	50
15	Liquid detergents connection.....	52
15.1	Connection scheme of liquid detergents.....	54
15.2	Electrical liquid detergents' connection.....	55
16	Steam connection.....	56
17	Air vent connection.....	57
17.1	Air vent connection for clean room installation.....	59
18	Note about the A.C. power.....	61
19	Feeder cable sections.....	61
20	Electricity power supply.....	63
21	Compressed air connection.....	65
21.1	Compressed air standard ISO 8573-1.....	66
22	Connectivity of the barrier washer.....	68
22.1	Process to follow with a pre equiped washer machine.....	69
22.2	Connectivity of the barrier washer with after sales kit.....	70
22.2.1	Contents of the kit.....	70
22.2.2	Required tools.....	70
22.2.3	Procedure to follow to connect the barrier washer with after sales kit.....	71
23	Function checks and settings at the first use.....	72
24	Explanation of washing symbols.....	79
24.1	Washing.....	79
24.2	Bleaching.....	79
24.3	Drying.....	80
24.4	Ironing.....	80

# Contents

---

24.5 Dry or water cleaning .....	80
25 Conversion of measurement units.....	82

The manufacturer reserves the right to make changes to design and component specifications.

# 1 Safety precautions



## CAUTION

READ THIS ENTIRE MANUAL BEFORE USAGE





**Inner drum doors correct closing is indicated by an audible click**

Before starting the machine, the doors'locking mechanism **MUST BE TESTED** :

- 1** Check that the locker is properly operating by pressing the safety latch alone.  
It must be free and the doors do not open.
- 2** Pushed in the doors inwards **without pressing the safety latch**.  
If the inner doors open, the safety latch does not work : call your Electrolux Professional service representative.  
**Note that the machine MUST NOT be used.**
- 3** Ensure that no textiles are jammed between the inner doors.



**1**



**2**









**DO NOT OVERLOAD THE MACHINE**

Please refer to the user manual for details

31110625\_GB



35 kg Max

70 kg max  
WB6 70



45 kg Max

90 kg max  
WB6 90



55 kg Max

110 kg max  
WB6 110

This machine should be installed in conformance to the health and safety regulations, and only used in a sufficiently aerated area. Check the instructions before installing or using the machine.



## CAUTION



Before any use, to retire all the parts needed to install the machine put in the drum , please follow these actions

1. connect compressed air.
2. Remove the side housing cabinet.
3. Push on the orange button of the D9/D10 distribution unit in the electric cabinet. (see drawing below)

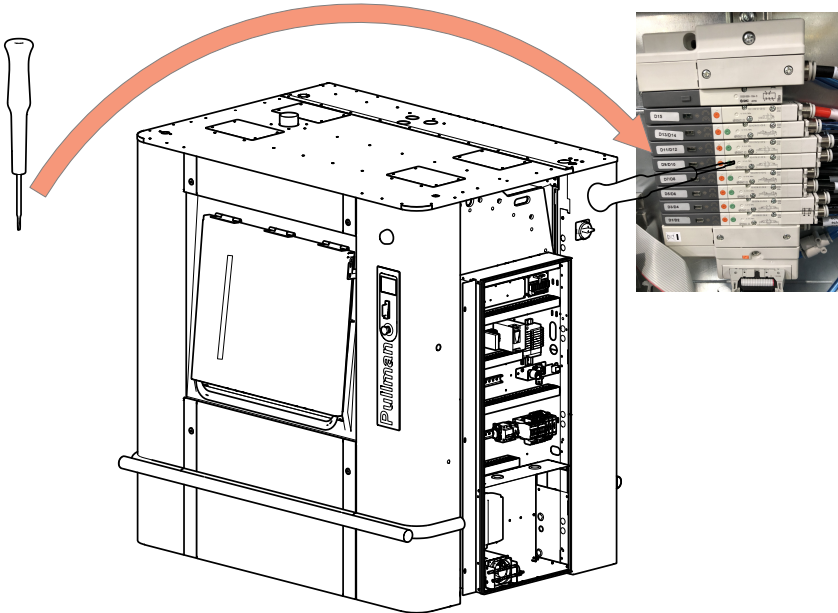

4. Open the loading door.
5. Open the drum doors , with precautions, maintain the 2 doors.
6. Get the package and instructions.

**CAUTION**

Users must have learnt how the machine operates.  
This device must not be installed in places accessible to the public.  
The machine is only intended for water-wash use.  
Do not allow minors to use the machine.  
Do not hose down the machine with water.  
Only use detergent intended for water-wash of textiles Never use dry cleaning agents.  
It is forbidden to wash textiles soaked with solvents.  
The machine's door lock must under no circumstances be bypassed.  
If the machine develops a fault, this must be reported to the person in charge as soon as possible. This is important both for your safety and that of others.  
**DO NOT MODIFY OR TAMPER WITH THIS APPLIANCE.**  
Servicing shall be carried out only by authorised personnel by **ELECTROLUX PROFESSIONAL**.  
Only original spare parts shall be used.  
When performing service or replacing parts, the power must be disconnected.  
When the power is disconnected, the operator must see that the machine is disconnected (that the plug is removed and remains removed) from any point to which he has access. If this is not possible, due to the construction or installation of the machine, a disconnection with a locking system in the isolated position shall be provided.  
In accordance with the wiring rules : mount a multi-pole switch prior to the machine to facilitate installation and service operations.  
In order to prevent damage to the electronics (and other parts) that may occur as the result of condensation, the machine should be placed in room temperature for 24 hours before being used for the first time.  
In case of a gas heated machine, do not assemble the machine on premises containing a dry cleaning machines or other similar machines.  
Please wash only items offering appropriate distribution inside the drum.  
Do not wash items such as mattresses or shoes.  
Call our technical departments before washing nonstandard items. Noncompliance with these instructions may void the manufacturer's guarantee in case of abuse of the washer-extractor.

**CAUTION**

For the following countries : AT, BE, BG, HR, CY, CZ, DK, EE, FI, FR, DE, GR, HU, IS, IE, IT, LV, LT, LU, MT, NL, NO, PL, PO, PT, RO, SK, SI, ES, SE, CH, TR, UK : This appliance shall not be installed where the public has access.  
For other countries : This appliance is not intended for use by persons (including children) with reduced physical, sensory or mental capabilities, or lack of experience and knowledge, unless they have been given supervision or instruction concerning use of the appliance by a person responsible for their safety and understand the hazards involved. Children should be supervised to ensure that they do not play with the appliance.

**IMPORTANT**

The identification plate is located on the right side near the main switch.

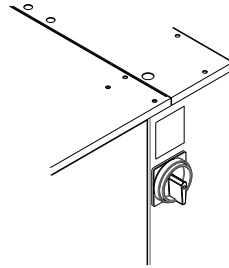

Never use the main switch as an emergency stop. Use it only when the machine does not work in progress. Instead of that, use the emergency stop buttons in both sides of the machine.

**IMPORTANT**

Sound pressure level is found in Technical data.

**CAUTION**

Your machine is equipped with an automatic weighing system which weighs the laundry during the loading and unloading cycle. For proper operation of this system, **you should not open the tank doors for the all duration of the wash program initiated** even if errors occurs.

**IMPORTANT**

Never try to open the outer drum door before the complete stop of the cage.

**CAUTION**

Disconnect all the sources of energy before any intervention on the machine.





The machines comply with the European Directive EMC (Electromagnetic Compatibility). They have been tested in laboratory and approved as such. It is so prohibited to add wires or nonshielded electric cables in the cabinets, strands or cables' troughs. Considering that the volume of the outer drum is superior to 150 litres, the standard kept for the electric part is the IN 60204.



### CAUTION



With AIDO(Automatic Inner Door Opening) option, Take care of the disc of the opening system above your head. Risk of cutting with the edge of the disc!!  
Take care also of the locking system on your side; risk of cutting with the edge of the plate!!



### CAUTION



When you put your hands into the drum, take care of the edge of the outer drum doors on yours sides. Risk of cutting with the edge of the metal plate!!



### CAUTION



The machine can work without the protective casing when the electric supply is not cut off.  
Interlock the main isolating switch with a padlock.  
Close the steam or gas inlet valves.



### IMPORTANT



Ensure that the machine is not loaded beyond its maximum capacity (70 kg (154 lb) for WB6 70 ; 90 kg (198 lb) for WB6 90 and 110 kg (242 lb) for WB6 110).

An excessive load has consequences for the lifetime of the machine's organs, as follows:

- Premature deterioration and failure of the suspension elements (springs, shock absorbers);
- Excessive fatigue of motorization elements (engine, belt);
- Rapid reduction of lifetime of drum bearings (rolling bearings);
- Opening and destruction of drum doors and tank doors during oil dehydration.

This is particularly important for your safety and that of others.

The consequence is an immediate cancellation of the warranty.



## THINK OF THE ENVIRONMENT!



The use and handling of chemical products such as detergent, chlorine, acids, descaling agents, etc may create hazards for health and environment ; the following precautions should be taken:

- Do not breathe the dusts or steam;
- Avoid contact with skin or eyes (may cause burns);
- In case of important spillage, wear a protecting mask, gloves, and eye protectors;
- Handle with care;
- Consult the use and first aid advice on the packing;
- Do not dispose pure products in the environment.



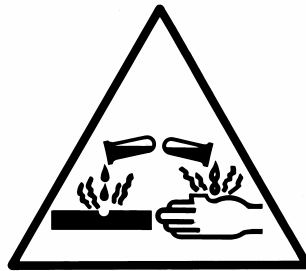

## WARNING



The use and handling of chemical products such as detergent, chlorine, acids, antiliming agents etc... may create hazards for health and environment ; the following precautions should be taken.





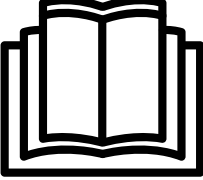

- Do not breathe the dusts or steam.
- Avoid contact with skin or eyes (may cause burns).
- In case of important spillage, wear a protecting mask, gloves, and eye protectors.
- Handle with care.
- Consult the use and first aid advice on the packings.
- Do not dispose pure products in the environment.

## 1.1 Symbols

	Caution.
	Caution, presence of dangerous current.
	Read the instructions before using the machine.

## 1.2 Personal protection equipment

Given below is a summary table of the Personal Protection Equipment (PPE) to be used during the various phases of the machine's service life.

Phase	Protection garments 	Safety footwear 	Gloves 	Glasses 	Ear protectors 	Mask 	Safety helmet 
Transport		X	O				
Handling		X	O				
Unpacking		X	O				
Installation		X	O				
Normal use	X	X	X	X			
Adjustments	O	X					
Routine cleaning	O	X	X	O			
Extraordinary cleaning	O	X	X	O			
Maintenance	O	X	O				
Dismantling	O	X	O				
Scrapping	O	X	O				

**Legend :** X : PPE required ; O : PPE available or to be used if necessary.

**Normal use :** Safety footwear must be defined for a use on a wet floor. And use glasses and gloves to manipulate chemical products.

## 1.3 Preliminary instructions



### WARNING



Risk of jamming when opening the lower door for unloading



### WARNING



Risk of jamming with trolley and lower door when opening (if trolley height = 900mm)

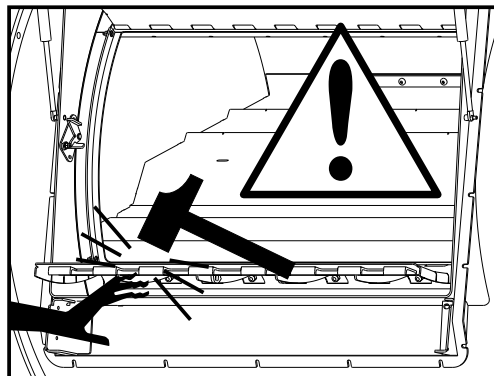

**WARNING**

Risk of the upper door being raised quickly on loading

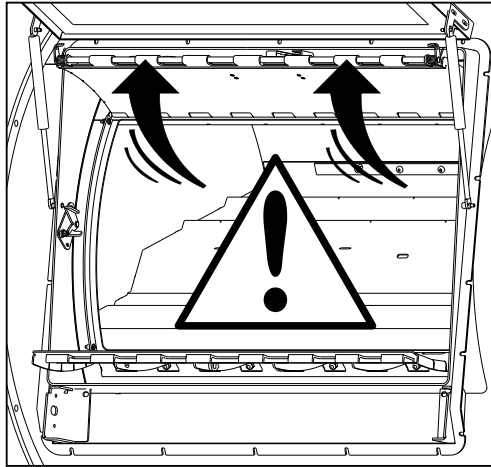
**WARNING**

After the installation, Send back the commissioning form ,signed document, to ElectroluxProfessional to validate the warranty of the product.

## 1.4 Data plate explanation

In this chapter, you will find the explanation of the different data input on the data plate of your product.

- Commercial name : Usual name of your product ( i.e. WB6–70).
- Type : Type of your product (you have the same on the Declaration of Conformity CE if delivered with CE certification).
- Model : Model of your product (can be different of commercial name ) (i.e WSBA6180H17 for commercial name WB6–20) .
- Serial Number : serial number of your product which indicate the week of the production of your product (the first 4 digit indicate the year and the week of production) and the plant where it has been produced (finish by 17)
- Product N°: Product number of your product.
- Date : The date of the end of manufacture of your product
- Capacity : for washer product, the maximum loaded weight of linen for your product (in kg)(i..e. 70 kg for WB6–70)
- Some technical data depending of the heating of your product : see list below :
- Some technical data depending of the voltage ordered.  
the voltage looks like that 380–415V 3 50–60Hz  
under this, you find the protection request for your product (i.e 16 A)
- Different logos are available on your data plate .  
They represent the different certification obtained for your product  
CE, EAC  
ETL intertek for USA and Canada countries
- QR code : when you scan it, you will be able to obtain the full documentation for your product (Complete installation and user manuals)
- Standardized protection index of your product : IP24D

**Electric heating :**

- P.Max : maximum power installed of your product
- Power of the motorization in kW and its isolation class (F) .
- Heating power in W .

Commercial name : WB6-70  
 Product N° : 9890430007  
 Serial N° : 4012000517  
 Type : WB6-70



Date : 22/02/2024

Electrolux Professional Laundry Systems France 10430 Rosières-près-Troyes - FRANCE



Commercial name : WB6-70  
 Type : WB6-70  
 Model : WB6-70

Serial N° : 4012000517  
 Product N° : 9890430007

Capacity : 70 kg  
 P.Max : 65700 W

11 kW Isol.Class. : F

54000 W

400 V 3 50-60 Hz

125 A



For safety reasons use only original spare parts.



IP24D Date : 22/02/2024

Made in France by  
 Electrolux Professional Laundry Systems France  
 10430 Rosières-près-Troyes - FRANCE



32101642E

Commercial name : WB6-70  
 Product N° : 9890430007  
 Serial N° : 4012000517  
 Type : WB6-70



Date : 22/02/2024

Electrolux Professional Laundry Systems France 10430 Rosières-près-Troyes - FRANCE



**Steam heating :**

## Left side

- P.Max : maximum power installed of your product
- Power of the motorization in kW and its isolation class (F) .
- Heating power in W .

## Right side

- P.Maxi. (kPa) maximum pressure

For additional information, do not hesitate to consult with our quality department.

Commercial name : WB6-70  
 Product N° : 9890430009  
 Serial N° : 3472000817  
 Type : WB6-70







Date : 08/02/2024

Electrolux Professional Laundry Systems France 10430 Rosières-près-Troyes - FRANCE



Commercial name : WB6-70  
 Type : WB6-70  
 Model : WB6-70

Serial N° : 3472000817  
 Product N° : 9890430009  
 Capacity : 70 kg  
 P.Max : 11700 W  
 11 kW Isol.Class. : F  
 W  
 400 V  3 50-60 Hz  
 32 A 



P. maxi. 600 kPa

For safety reasons use only original spare parts.



IP24D Date : 08/02/2024

Made in France by  
 Electrolux Professional Laundry Systems France  
 10430 Rosières-près-Troyes - FRANCE



32101642E

Commercial name : WB6-70  
 Product N° : 9890430009  
 Serial N° : 3472000817  
 Type : WB6-70



Date : 08/02/2024

Electrolux Professional Laundry Systems France 10430 Rosières-près-Troyes - FRANCE





## 1.5 Warranty terms and exclusions

If the purchase of this product includes warranty coverage, warranty is provided in line with local regulations and subject to the product being installed and used for the purposes as designed, and as described within the appropriate equipment documentation.

Warranty will be applicable where the customer has used only genuine spare parts and has performed maintenance in accordance with user and maintenance documentation made available in paper or electronic format.

strongly recommends using approved cleaning, rinse and descaling agents to obtain optimal results and maintain product efficiency over time.

The warranty does not cover:

- service trips cost to deliver and pick up the product;
- installation;
- training on how to use/operate;
- replacement (and/or supply) of wear and tear parts unless resulting from defects in materials or workmanship reported within one (1) week from the failure;
- correction of external wiring;
- correction of unauthorized repairs as well as any damages, failures and inefficiencies caused by and/or resulting from:
  - insufficient and/or abnormal capacity of the electrical systems (current/voltage/frequency, including spikes and/or outages);
  - inadequate or interrupted water supply, steam, air, gas (including impurities and/or other that does not comply with the technical requirements for each appliance);
  - plumbing parts, components or consumable cleaning products that are not approved by the manufacturer;
  - customer's negligence, misuse, abuse and/or non-compliance with the use and care instructions detailed within the appropriate equipment documentation;
  - improper or poor: installation, repair, maintenance (including tampering, modifications and repairs carried out by third parties not authorized third parties) and modification of safety systems;
  - Use of non-original components (e.g.: consumables, wear and tear, or spare parts);
  - environment conditions provoking thermal (e.g. overheating/freezing) or chemical (e.g. corrosion/oxidation) stress;
  - foreign objects placed in- or connected to- the product;
  - accidents or force majeure;
  - transportation and handling, including scratches, dents, chips, and/or other damage to the finish of the product, unless such damage results from defects in materials or workmanship and is reported within one (1) week of delivery unless otherwise agreed;
- product with original serial numbers that have been removed, altered or cannot be readily determined;
- replacement of light bulbs, filters or any consumable parts;
- any accessories and software not approved or specified by .

Warranty does not include scheduled maintenance activities (including the parts required for it) or the supply of cleaning agents unless specifically covered within any local agreement, subject to local terms and conditions.

Check on website the list of authorized customer care.

## 2 Environmental information

Concerned by providing the end user with useful and necessary environmental information, we wish to precise:

- Data about energetic consumptions, wastes (atmospheric and liquid) and sound level are indicated in the paragraph «Technical characteristics».
- Foreseeing its recycling, this machine is fully dismantlable.
- This machine is free from any asbestos.
- In conformity with French regulations.
- In the other countries, we recommend that you comply with the legislation in force in the country where the machine is installed.
- In France, all owners of packing waste producing a weekly volume below 1100 litres can forward these to the local collection and treatment department. If exceeding this volume, the owners of packing waste will ensure their valuation by reuse, recycling or, any other action aiming at producing reusable materials or energy... or provide them contractually to a certified intermediate authorised to transport, trade or broke waste.

Therefore, this forbid:

- land filling raw waste;
- open air burning or incineration without energy collection.
- Packaging of our machines are according with the french legislation related to environment requirements.

For additional information, do not hesitate to consult with our environmental department.

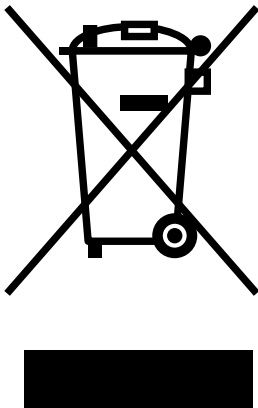

### Scrapping of machine

When the machine is no longer to be used, it must be submitted to a recycling facility for destruction.

The majority of the components in the machine can be reused, but it also contains other materials that must be taken care of in the correct way.

Therefore, never mix the machine or its parts with domestic waste as this may lead to health hazards or damage to the environment.

### 3 Locking and tagging procedure

A red insert at the beginning of this instruction handbook schematically shows the locking and tagging procedure described below. If you wish, you can detach this insert and display it close to the machine to remind maintenance personnel of the safety instructions.

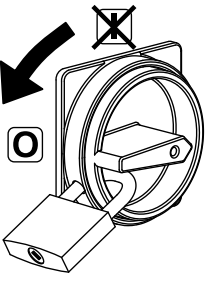
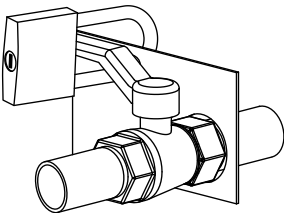
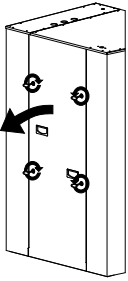
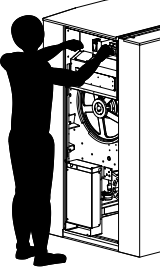
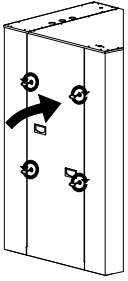
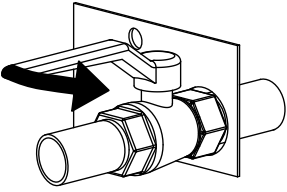
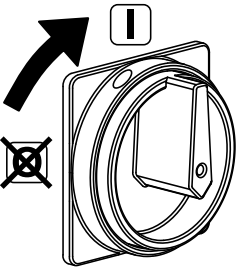
1		<p>Always respect items 2, 3 and 4 carefully before doing any repair or maintenance work on the machine.</p>		
2		<p>Put the main switch to Off and lock the handle with a padlock in one of the three holes provided for this purpose.</p>		<p>Close the stop valves for the other supplies (steam, gas, thermal fluid, compressed air) to stop and lock their handle with a padlock.</p>
3		<p>Open the fixed protectors (casings, doors) with the key provided or a special tool.</p>		<p>Do the maintenance.</p>
4		<p>Close and carefully lock the fixed protectors.</p>		
5			<p>Unlock the stop valves and the main switch.</p>	

## 4 Handling



### Important



It is obligatory that all these operations are undertaken by handling specialists.

Before any handling, check that the four transport locks fitted are still in place and well-tightened. To do so, remove the side casings and check presence of four locks (B) and the down casings for the four locks (A).

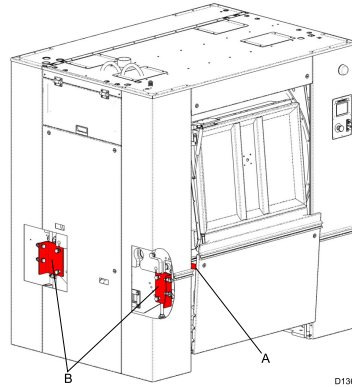

### Caution



To handle the machine, you must imperatively reassemble the transport bridles and dis engage the load cells (proceed in reverse order or "remove of the transport locks fitted" )

### 4.1 Lifting with a fork-lift truck



### Warning



You should never handle the machine in its longitudinal side (any other than shown on the drawing below) with a fork-lift truck. Important risk of parts deterioration for those fixed under the machine.

This can be carried out from the front or back, and at the centre of the machine using forks with minimum length of 1.50 m (59")

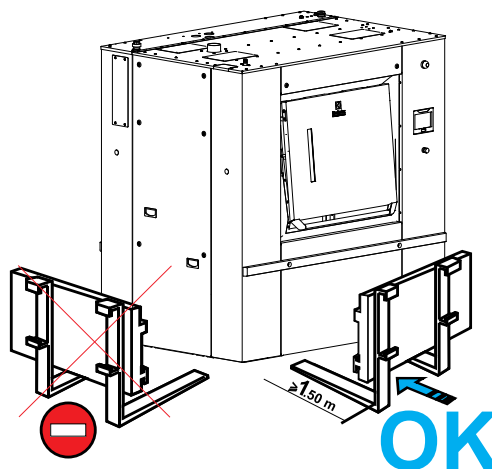

### 4.2 Lifting with handlings straps

Lifting in that case can only be done with handling straps (minimum capacity 3000 daN / 6600 lb) which bear weight of the machine.



### Caution



Make sure to place the straps correctly to avoid any bending of parts of the machine.

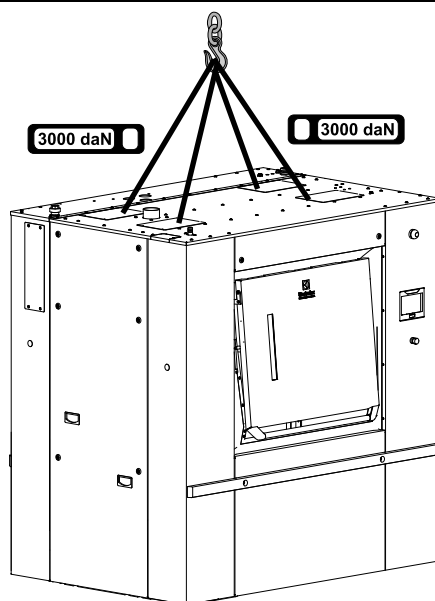

### Caution



In order to avoid any bending of casings, you should never climb and stand on top of the machine.

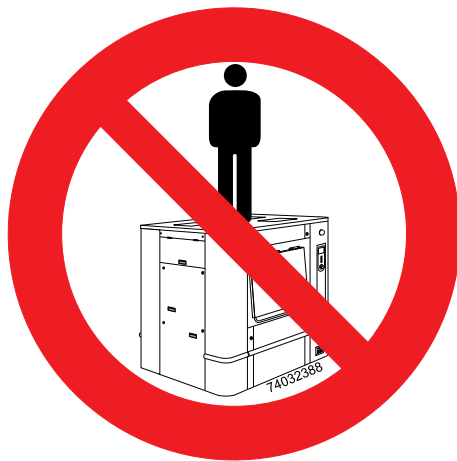

## 5 Packing-Weight

### 5.1 Packing

Packing dimensions in mm/in	Size A	Size B	Size C
Washer extractor type WB6 70	1710 / 68"	1710 / 68"	2330 / 92"
Washer extractor type WB6 90	1710 / 68"	1970 / 78"	2330 / 92"
Washer extractor type WB6 110	1710 / 68"	2180 / 86"	2330 / 92"

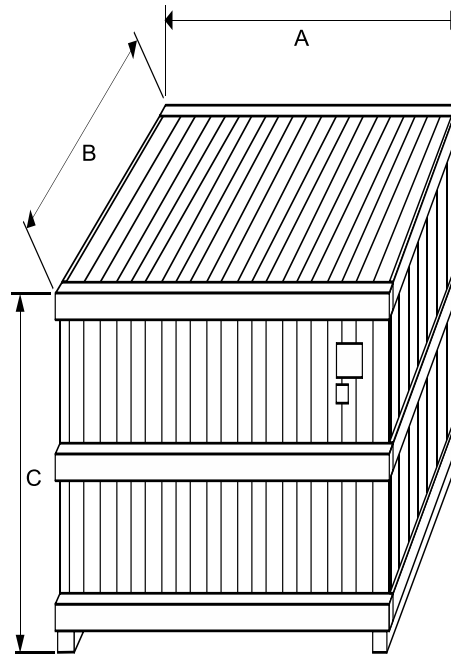

## 5.2 Weight

Weight in kg/lb (machine + crate)*	Electrical heating	Steam/ Thermal fluid heating
Washer extractor type WB6 70	2900 / 6395	2900 / 6395
Washer extractor type WB6 90	3100 / 6836	3100 / 6836
Washer extractor type WB6 110	3280 / 7233	3280 / 7233

\* Precise weight depends on accessories fitted.

## 6 Technical characteristics

### 6.1 Explanation of following installation drawings

Letter	Description
D	Hot water connection
E	Cold hard water connection
F	Cold soft water connection
G	Steam inlet
H1	1st drain connection
H2	2nd drain connection
I	Waste water collector
J	Air vent hole
K	Compressed air inlet
L	Main switch to connect main cable
M	Electric cable
N	Stuffing box for main cable
O	Barrier partition
P	Frame
R	Aseptic seal
T	Liquid detergents connection
V	Thermic fluid inlet
W	Thermic fluid return

### 6.2 Washer extractor type WB6 70

One door WB6 70: Drawing 07100158

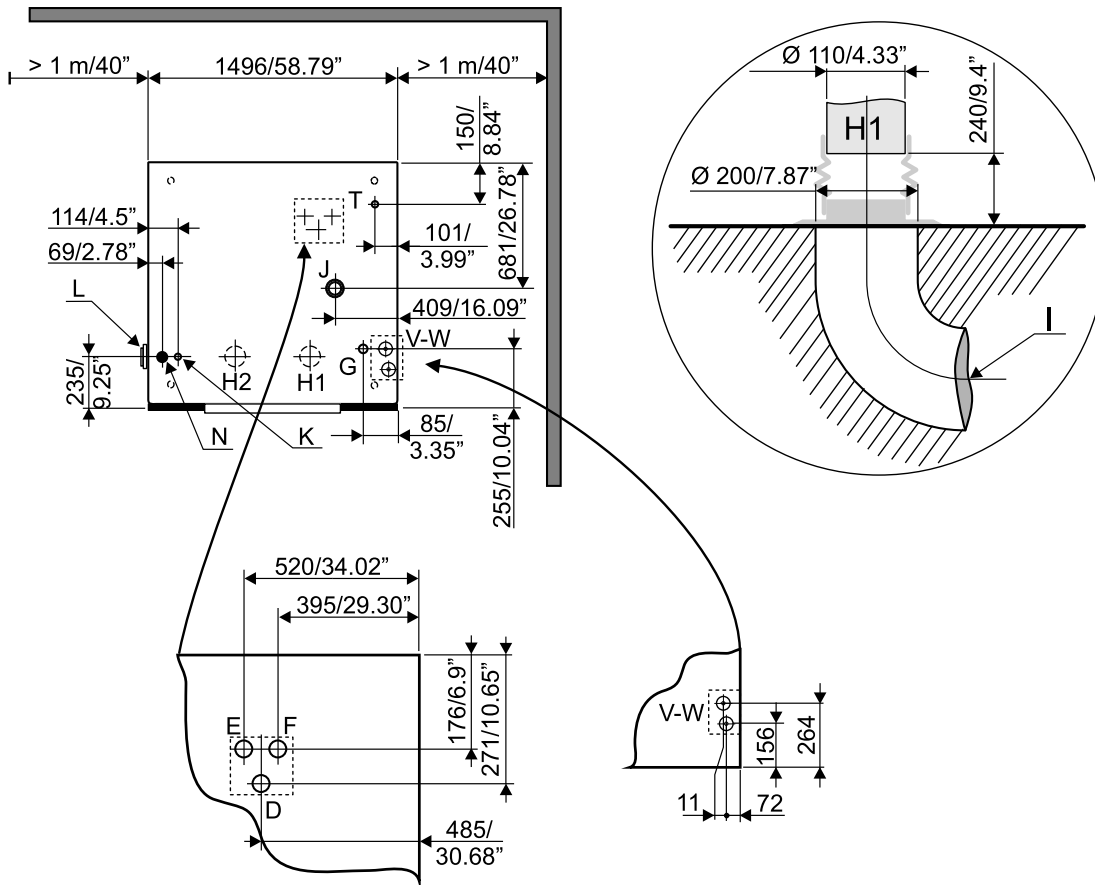
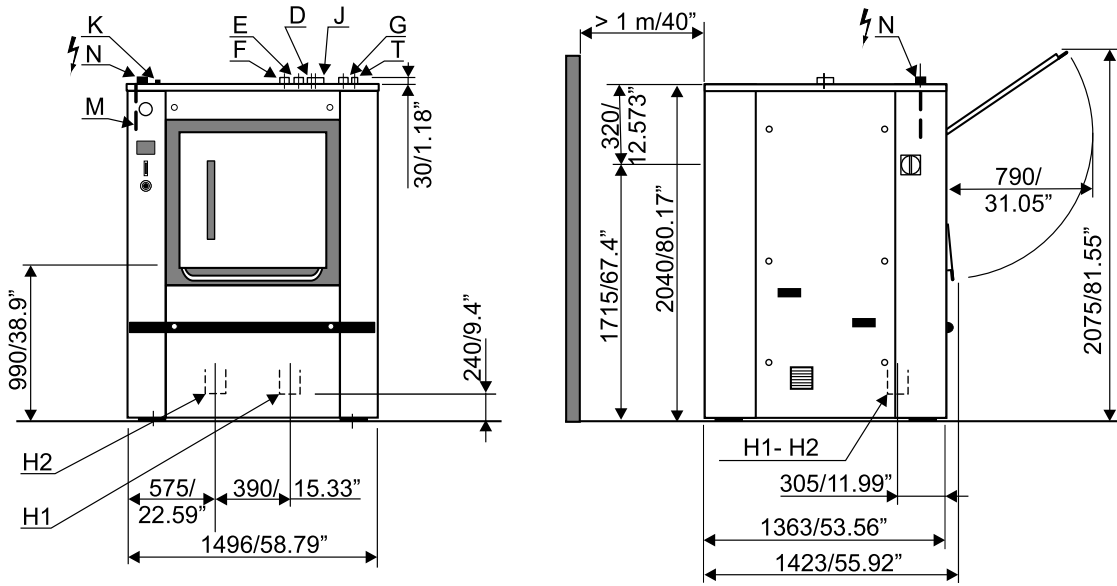





Opening inner drum doors (LxH)	mm	670°490	670x490
Opening outer drum door (LxH)	mm	728°698	728°698
G-factor, max.		300	300
Specific load 1/10 <sup>1</sup> ISO 93 98-4 standard type C	kg / lb	70 / 154	
Floor area	m <sup>2</sup>	2.04	2.04
Max. unbalance	kg	15	15
Net weight	daN	2530*	2530*
Weight loaded (high level)	daN	3010	3010
Water volume, washing (low level)	l	185	185
Water volume, washing (high level)	l	370	370
Heat loss		3 % of installed heating power	

\* Precise weight depends on accessories fitted.

**6.3 Connections WB6 70 :**

<b>Water</b>	Units	<b>One door</b>	<b>Barrier</b>
Water valves connection	mm-BSP	DN32–1"1/4"	DN32–1"1/4"
Capacity at 250 kPa	l/min	200	200
Functioning limits for water valve	kPa	50–300	50–300
Water consumption for a wash program <sup>1</sup>	l	720	720

<b>Drain</b>	Units	<b>One door</b>	<b>Barrier</b>
Drain connection, outer $\varnothing$ (H1 on drawings)	mm	110	110
Double drain connection (option) outer $\varnothing$ (H2 on drawings)	mm	110	110
Maximum drain flow rate	l/min	380	380
Waste water collector	DN-mm	200	200

<b>Air vent</b>	Units	<b>One door</b>	<b>Barrier</b>
Air vent connection, outer $\varnothing$	mm	80	80

<b>Liquid detergents</b>	Units	<b>One door</b>	<b>Barrier</b>
Liquid detergents connection, outer $\varnothing$	mm	25	25

<b>Steam</b>	Units	<b>One door</b>	<b>Barrier</b>
Steam inlet, standard	mm-BSP	DN25–1"	DN25–1"
Steam inlet, low pressure	mm-BSP	DN32–1"1/4"	DN32–1"1/4"
Recommended steam pressure	kPa	300–600	300–600
Recommended steam pressure (low pressure heating)	kPa	less than 50	less than 50
Functioning limits for steam valve (not for low pressure)	kPa	100–600	100–600
Steam instantaneous flow rate at 600 kPa	kg/h	240	240
Steam consumption for a normal cycle <sup>1</sup> ISO 93 98–4 standard type C	kg at 600 kPa	24	24
Steam consumption for a normal cycle <sup>1</sup> ISO 93 98–4 standard type C	kg at 50 kPa	26.5	26.5

<b>Indirect steam</b>	Units	<b>One door</b>	<b>Barrier</b>
Thermic fluid inlet or indirect steam heating	mm-BSP	DN20–3/4"	DN20–3/4"
Thermic fluid return or indirect steam heating	mm-BSP	DN20–3/4"	DN20–3/4"
Maximum supply pressure	kPa	400	400
Inner volume thermic fluid	l	8	8

1. ISO 93 98–4 standard type C.

---

<b>Electricity</b>	Units	<b>One door</b>	<b>Barrier</b>
Supply voltage	V	380/415	380/415
Frequency	Hz	50/60	50/60
Electric cable (section)	mm <sup>2</sup>	See chapter "Feeder cable section"	
Rated electric power, electric heating	kW	65.7	65.7
Rated electric power, steam heating / indirect steam heating	kW	11.7	11.7

<b>Heating</b>	Units	<b>One door</b>	<b>Barrier</b>
Installed heating power, electric heating	kW	54	54
Electric consumption for a standardized cycle, electric heating	kWh	11.62	11.62
Electric consumption for a standardized cycle, steam heating	kWh	1.86	1.86

<b>Floor load</b>	Units	<b>One door</b>	<b>Barrier</b>
Max transmitted floor load	daN	3600	3600
Max. pressure transmitted to floor	kPa	144	144

<b>Compressed air</b>	Units	<b>One door</b>	<b>Barrier</b>
Compressed air inlet	mm	6/8	6/8
Min./max. compress air pressure	bar	5.5/7	5.5/7
Consumption	l/h	50	50

### 6.4 Washer extractor type WB6 90

One door WB6 90: Drawing 07100160

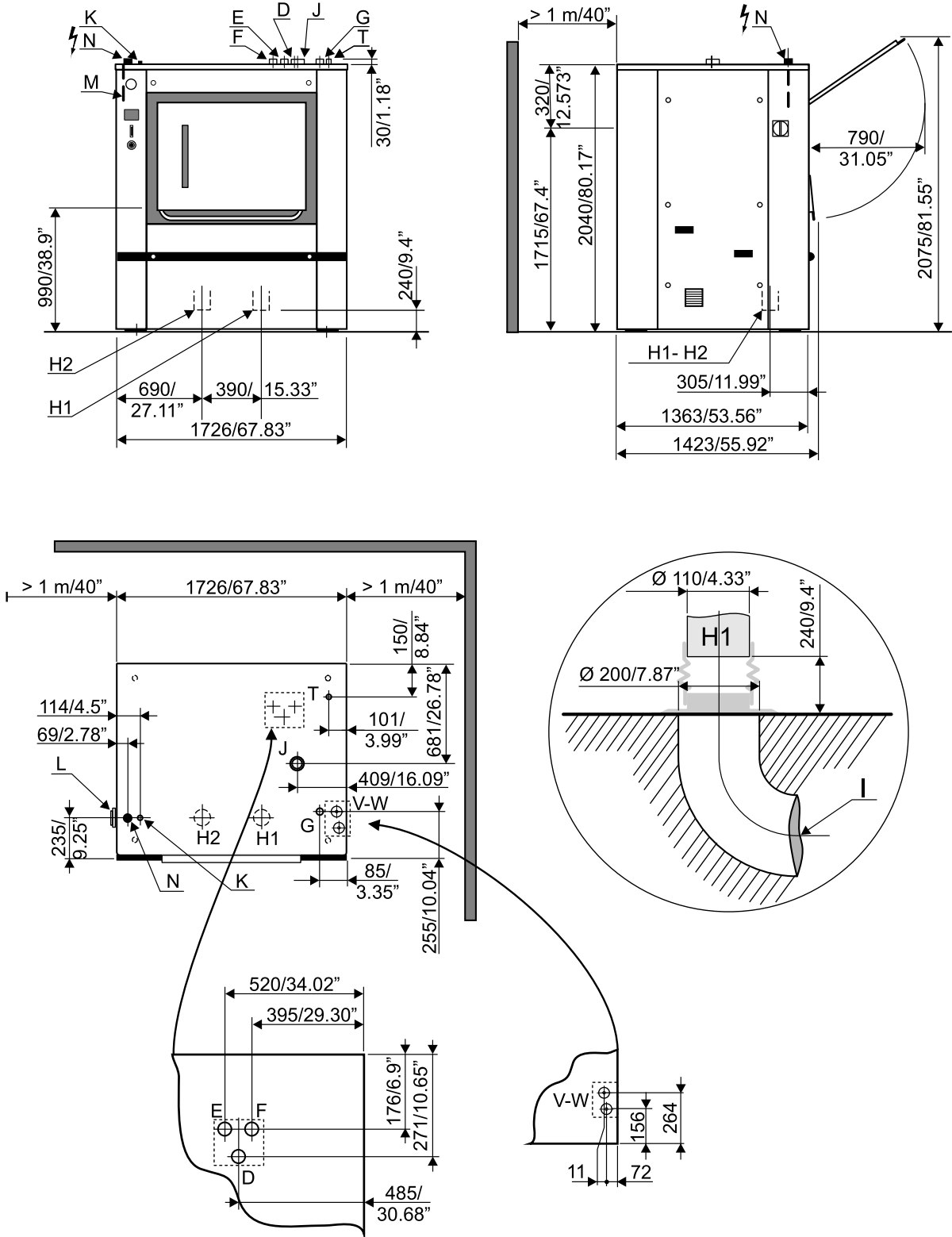

Barrier WB6 90: Drawing 07100159

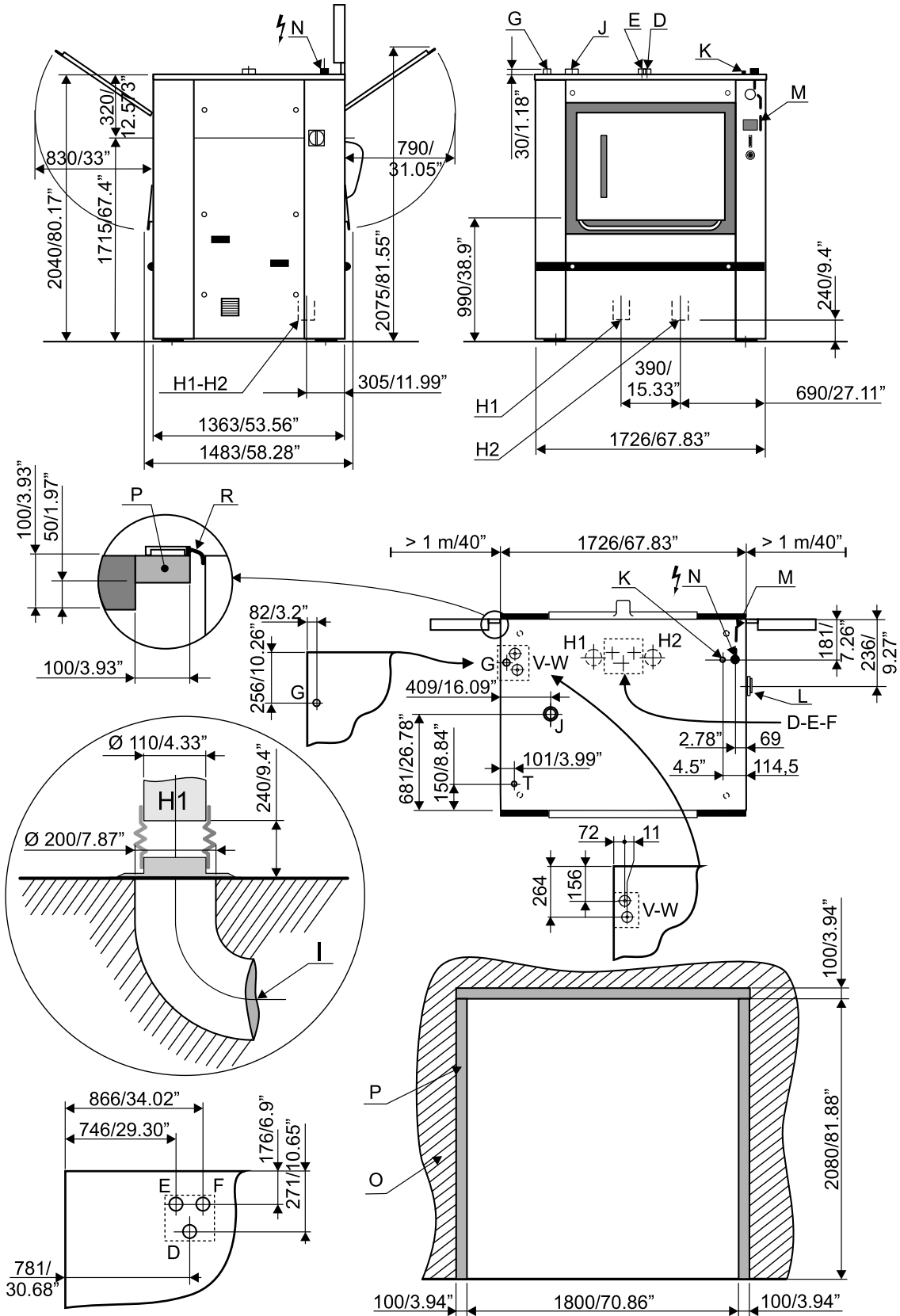

Washer extractor type WB6 90 (Diagram N° 07100159 and 07100160)			
	Units	One door	Barrier
Drum diameter	mm / "	1050 / 41.33"	1050 / 41.33"
Drum length	mm / "	1026 / 40.39"	1026 / 40.39"
Drum volume	litre	890	890

Opening inner drum doors (LxH)	mm	900*490	900x490
Opening outer drum door (LxH)	mm	958*698	958*698
G-factor, max.		300	300
Specific load 1/10 <sup>1</sup> ISO 93 98-4 standard type C	kg / lb	90 / 198	
Floor area	m <sup>2</sup>	2.35	2.35
Max. unbalance	kg	15	15
Net weight	daN	2725*	2725*
Weight loaded (high level)	daN	3345	3345
Water volume, washing (low level)	l	220	220
Water volume, washing (high level)	l	440	440
Heat loss		3 % of installed heating power	

\* Precise weight depends on accessories fitted.



**6.5 Connections WB6 90 :**

<b>Water</b>	Units	<b>One door</b>	<b>Barrier</b>
Water valves connection	mm-BSP	DN32–1"1/4"	DN32–1"1/4"
Capacity at 250 kPa	l/min	200	200
Functioning limits for water valve	kPa	50–300	50–300
Water consumption for a wash program <sup>2</sup>	l	931	931

<b>Drain</b>	Units	<b>One door</b>	<b>Barrier</b>
Drain connection, outer $\varnothing$ (H1 on drawings)	mm	110	110
Double drain connection (option) outer $\varnothing$ (H2 on drawings)	mm	110	110
Maximum drain flow rate	l/min	380	380
Waste water collector	DN-mm	200	200

<b>Air vent</b>	Units	<b>One door</b>	<b>Barrier</b>
Air vent connection, outer $\varnothing$	mm	80	80

<b>Liquid detergents</b>	Units	<b>One door</b>	<b>Barrier</b>
Liquid detergents connection, outer $\varnothing$	mm	25	25

<b>Steam</b>	Units	<b>One door</b>	<b>Barrier</b>
Steam inlet, standard	mm-BSP	DN25–1"	DN25–1"
Steam inlet, low pressure	mm-BSP	DN32–1"1/4"	DN32–1"1/4"
Recommended steam pressure	kPa	300–600	300–600
Recommended steam pressure (low pressure heating)	kPa	less than 50	less than 50
Functioning limits for steam valve (not for low pressure)	kPa	100–600	100–600
Steam instantaneous flow rate at 600 kPa	kg/h	240	240
Steam consumption for a normal cycle <sup>1</sup> ISO 93 98–4 standard type C	kg at 600 kPa	32	32
Steam consumption for a normal cycle <sup>1</sup> ISO 93 98–4 standard type C	kg at 50 kPa	35	35

<b>Indirect steam</b>	Units	<b>One door</b>	<b>Barrier</b>
Thermic fluid inlet or indirect steam heating	mm-BSP	DN20–3/4"	DN20–3/4"
Thermic fluid return or indirect steam heating	mm-BSP	DN20–3/4"	DN20–3/4"
Maximum supply pressure	kPa	400	400
Inner volume thermic fluid	l	9	9

2. ISO 93 98–4 standard type C.

---

<b>Electricity</b>	Units	<b>One door</b>	<b>Barrier</b>
Supply voltage	V	380/415	380/415
Frequency	Hz	50/60	50/60
Electric cable (section)	mm <sup>2</sup>	See chapter "Feeder cable section"	
Rated electric power, electric heating	kW	87.7	87.7
Rated electric power, steam heating / indirect steam heating	kW	15.7	15.7

<b>Heating</b>	Units	<b>One door</b>	<b>Barrier</b>
Installed heating power, electric heating	kW	72	72
Electric consumption for a standardized cycle, electric heating	kWh	14.67	14.67
Electric consumption for a standardized cycle, steam heating	kWh	2.3	2.3

<b>Floor load</b>	Units	<b>One door</b>	<b>Barrier</b>
Max transmitted floor load	daN	4100	4100
Max. pressure transmitted to floor	kPa	164	164

<b>Compressed air</b>	Units	<b>One door</b>	<b>Barrier</b>
Compressed air inlet	mm	6/8	6/8
Min./max. compress air pressure	bar	5.5/7	5.5/7
Consumption	l/h	50	50

### 6.6 Washer extractor type WB6 110

One door WB6 110: Drawing 07100162

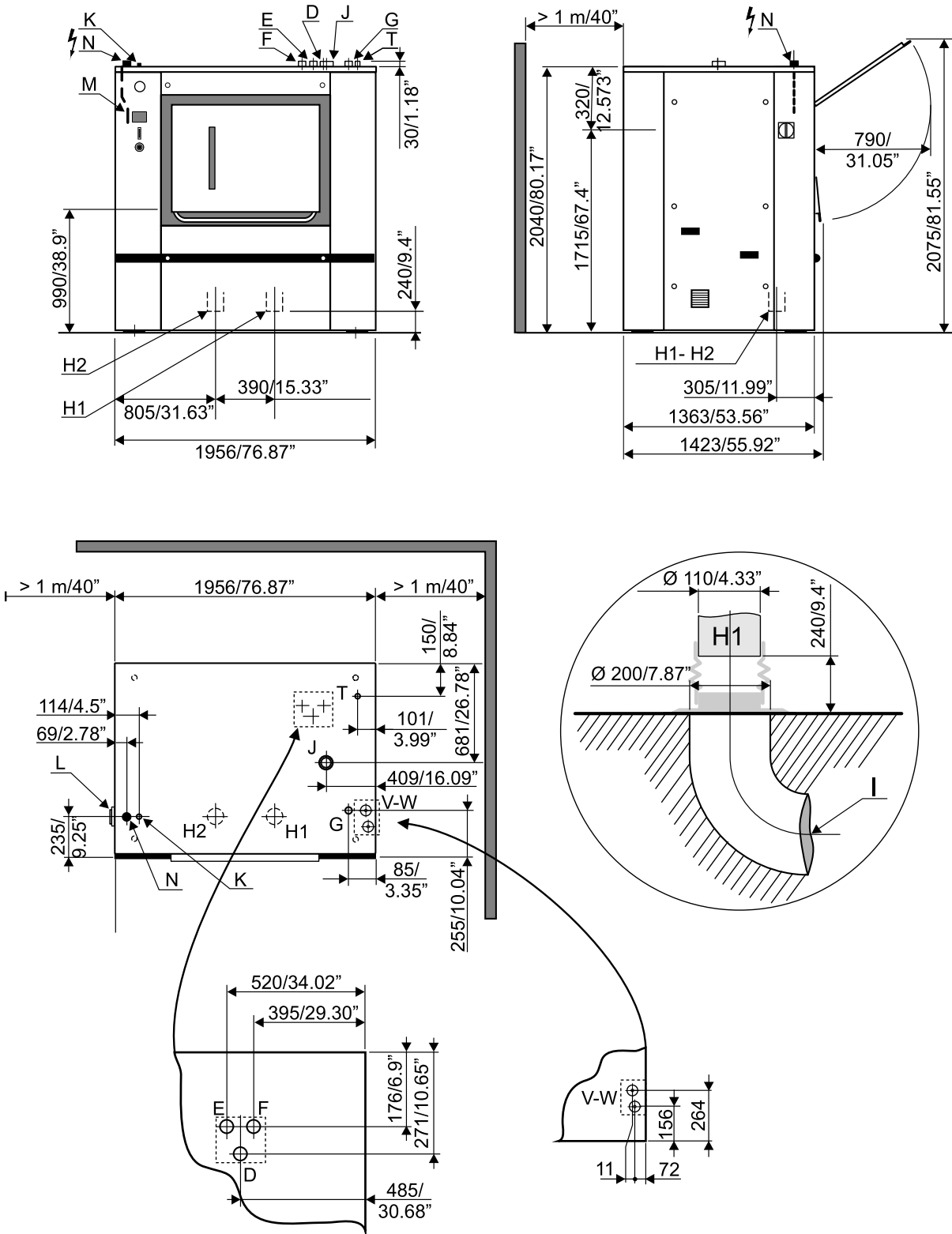

Barrier WB6 110: Drawing 07100161

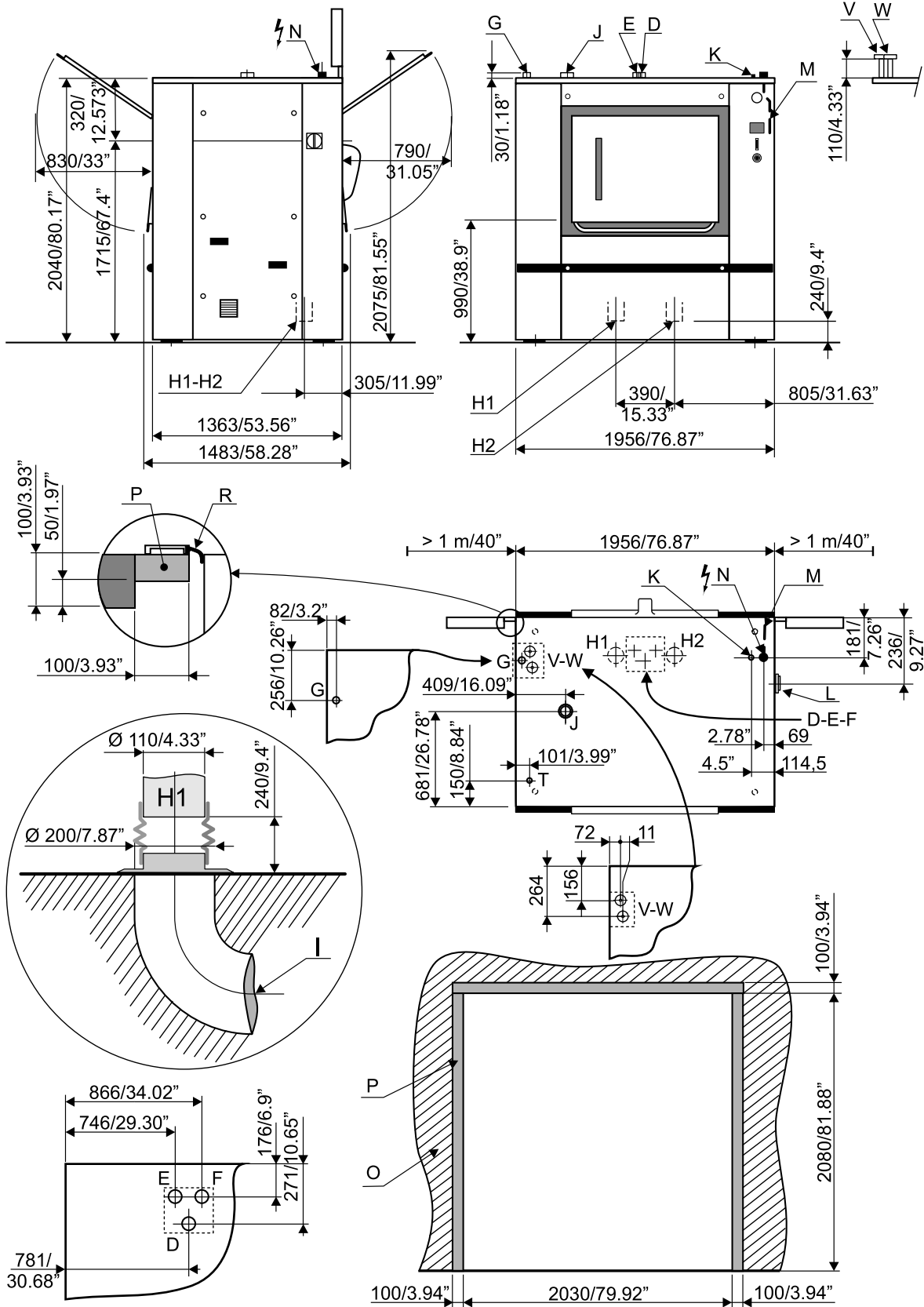

Washer extractor type WB6 110 (Diagram N° 07100161 and 07100162)			
	Units	One door	Barrier
Drum diameter	mm / "	1050 / 41.33"	1050 / 41.33"
Drum length	mm / "	1256 / 49.45"	1256 / 49.45"

Drum volume	litre	1080	1080
Opening inner drum doors (LxH)	mm	900*490	900x490
Opening outer drum door (LxH)	mm	958*698	958x698
G-factor, max.		300	300
Specific load 1/10 <sup>1</sup> ISO 93 98-4 standard type C	kg / lb	110 / 242	
Floor area	m <sup>2</sup>	2.67	2.67
Max. unbalance	kg	15	15
Net weight	daN	2850*	2850*
Weight loaded (high level)	daN	3608	3608
Water volume, washing (low level)	l	300	300
Water volume, washing (high level)	l	600	600
Heat loss		3 % of installed heating power	

\* Precise weight depends on accessories fitted.

**6.7 Connections WB6 110 :**

<b>Water</b>	Units	<b>One door</b>	<b>Barrier</b>
Water valves connection	mm-BSP	DN32–1"1/4"	DN32–1"1/4"
Capacity at 250 kPa	l/min	200	200
Functioning limits for water valve	kPa	50–300	50–300
Water consumption for a wash program <sup>3</sup>	l	1149	1149

<b>Drain</b>	Units	<b>One door</b>	<b>Barrier</b>
Drain connection, outer $\varnothing$ (H1 on drawings)	mm	110	110
Double drain connection (option) outer $\varnothing$ (H2 on drawings)	mm	110	110
Maximum drain flow rate	l/min	380	380
Waste water collector	DN-mm	200	200

<b>Air vent</b>	Units	<b>One door</b>	<b>Barrier</b>
Air vent connection, outer $\varnothing$	mm	80	80

<b>Liquid detergents</b>	Units	<b>One door</b>	<b>Barrier</b>
Liquid detergents connection, outer $\varnothing$	mm	25	25

<b>Steam</b>	Units	<b>One door</b>	<b>Barrier</b>
Steam inlet, standard	mm-BSP	DN25–1"	DN25–1"
Steam inlet, low pressure	mm-BSP	DN32–1"1/4"	DN32–1"1/4"
Recommended steam pressure	kPa	300–600	300–600
Recommended steam pressure (low pressure heating)	kPa	less than 50	less than 50
Functioning limits for steam valve (not for low pressure)	kPa	100–600	100–600
Steam instantaneous flow rate at 600 kPa	kg/h	240	240
Steam consumption for a normal cycle <sup>1</sup> ISO 93 98–4 standard type C	kg at 600 kPa	36	36
Steam consumption for a normal cycle <sup>1</sup> ISO 93 98–4 standard type C	kg at 50 kPa	39	39

<b>Indirect steam</b>	Units	<b>One door</b>	<b>Barrier</b>
Thermic fluid inlet or indirect steam heating	mm-BSP	DN20–3/4"	DN20–3/4"
Thermic fluid return or indirect steam heating	mm-BSP	DN20–3/4"	DN20–3/4"
Maximum supply pressure	kPa	400	400
Inner volume thermic fluid	l	10	10

3. ISO 93 98–4 standard type C.

---

<b>Electricity</b>	Units	<b>One door</b>	<b>Barrier</b>
Supply voltage	V	380/415	380/415
Frequency	Hz	50/60	50/60
Electric cable (section)	mm <sup>2</sup>	See chapter "Feeder cable section"	
Rated electric power, electric heating	kW	91	91
Rated electric power, steam heating / indirect steam heating	kW	19	19



Heating	Units	One door	Barrier
Installed heating power, electric heating	kW	72	72
Electric consumption for a standardized cycle, electric heating	kWh	17.71	17.71
Electric consumption for a standardized cycle, steam heating	kWh	2.4	2.4

Floor load	Units	One door	Barrier
Max transmitted floor load	daN	4450	4450
Max. pressure transmitted to floor	kPa	178	178

Compressed air	Units	One door	Barrier
Compressed air inlet	mm	6/8	6/8
Min./max. compress air pressure	bar	5.5/7	5.5/7
Consumption	l/h	50	50

## 7 Sound levels

The sound power level of the machine is determined by using ISO 3747:2012.

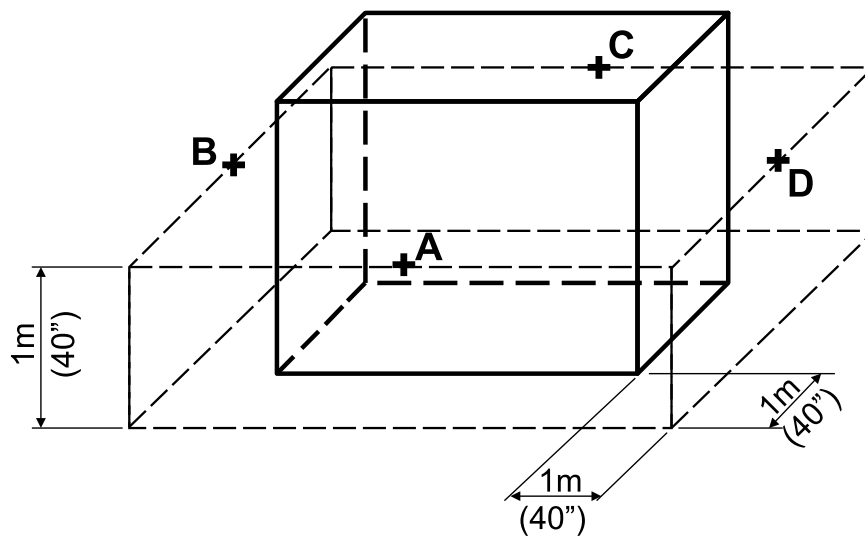

According to test code EN50571 : 2013 annex CC, the sound power level at extraction and during washing are according to the table:

Airborne noise emitted by the machine (values established from measurements made on machine at points A, B, C, and D)

Weighted sound pressure level in dB (A)	Washer 700 (Without insulation)		Washer 900 (Without insulation)		Washer 1100 (Without insulation)	
	Washing	High spin extraction	Washing	High spin extraction	Washing	High spin extraction
A	63.5	82.2	63.5	82	66	81.5
B	64	81.3	64.2	81	66	81.5
C	63	83.9	63.8	83	67	83
D	64	82.7	64.2	83	67	83



## 8 Working place lighting

The lighting should be designed so as to avoid eye strain for the operator ; it should be uniform without any glare, and should be sufficient to detect any hazards.

The average lighting value on the working place recommended by the clothing industry for inspecting linen is **500 lux**. Whenever possible, the working place should be illuminated by daylight.

## 9 Supplies

Take the box placed inside of the inner drum.

	<h3>Important</h3>	
<p>you must connect the compressed air to unlock the loading door. Then push on the orange button of the D9/D10 distribution unit in the electric cabinet. So you can access in the drum.</p>		

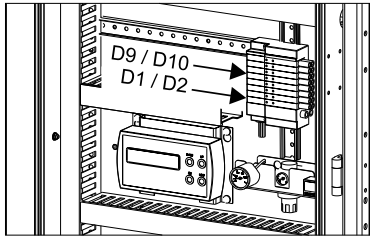

1. Accessories delivered with each machine
  - 1 instruction handbook + spare parts catalogue + 2 electrical schematics
  - 3 keys for casings
  - 2 or 3 stainless steel flexible pipes 3/4" + 4 or 6 fibre seals
  - 2 or 3 waters filters 1"
  - 2 or 3 male nipples 1"
  - 1 connection bellow  $\varnothing$  110 + 1 collar
  - 1 hose  $\varnothing$  110 mm + 1 collar for drain
  - 1 connection nozzle
  - 4 fixing dowels
  - 4 bolsters + 4 wedges (see explanation below for installation)
  
2. Accessories delivered with each steam heating machine
  - 1 steam electrovalve
  - 1 steam flexible
  - 1 steam filter
  - 1 pipe union
  
3. Accessories delivered with each gas heating machine
  - 4 meters blue flexible pipes
  - 2 pipes  $\varnothing$  125 mm (5"), length 500 mm (20") to be connect at the chimney
  - 1 T-square pipe  $\varnothing$  125 mm (5") and an anti-bursting chimney regulator to be connected over the gas exchanger
  - 1 draught accelerator to extract the exhaust of burn gas, to be connected at the chimney (in 3 parts)
  - 4 collars  $\varnothing$  40–60
  
4. Accessories delivered with each barrier washers
  - 1 rubber seal + aluminium extruded sections + 40 screws
  - 4 flange safety locks (machines with weighing equipment)
  - 1 opening inner drum lever (with manual opening door)
  - 1 kit screws ski WPB4–WB6P (replacement every 2 years)

## 10 Mechanical installation

Depending on its destination, the washer extractor is delivered bare or may be placed on a transport pallet and/or packed with plastic film.

In some cases, it may be delivered in a crate, or in maritime packing (wood box).

### 10.1 Unpacking

Take off the plastic film or remove the four wood socles with a spanner..

Please refer to the handling chapter in this instruction handbook for a description of handling operations.



### Important



Check that no damage has been caused during transport.

### 10.2 Installation

The installation must be done by competent technicians in accordance with local codes and regulations. When there are not local codes and regulations, the installation **must be comply** with European standards applicable.

The machine must be installed on a perfectly even surface, strong and horizontal, capable resisting to the efforts shown in the technical characteristics.

Adjustment of the machine by addition of level plate should be avoided.

Control the horizontal level using a water level placed on the machine's sole.

Place the washer extractor so that it is easy for the user and the service technician to do their work.

Leave at least 1 m (40") (**according to the recommendation in standard EN 60204**) between the machine, a wall or any other machine at the sides.

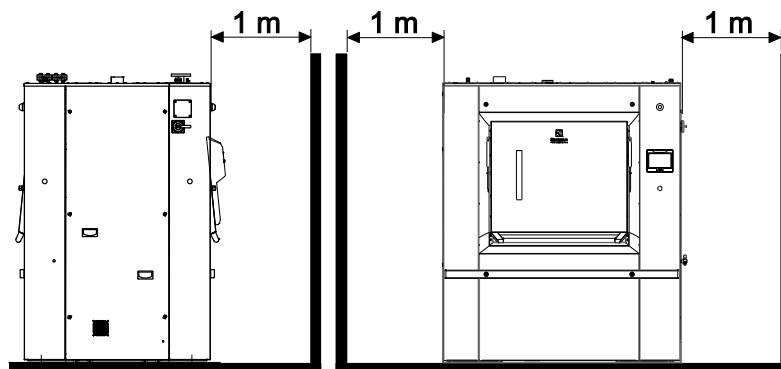

### 10.3 Installing the shock absorber plates

Preparation of the ground and the machine.

- Carefully degrease the ground and the machine's base plates.

Positioning the shock absorber plates.

- Place each shock absorber plate (P) at its respective location (see diagram) raising each of the machine's support points in series and taking care to let the plate inside of the base plates.

Commissioning the machine

- Time: before commissioning the machine, each support point must be embedded by being crushed in by the plate's upper layer and the lower layer must have been pushed into the porosity in the ground. The crushing time is 2 hours at an ambient temperature of 18 °C.



### Warning



Electrical safety device.

As rubber is a very good electric insulating material, the earthing of the machine is compulsory.

Moving machines sealed with the shock absorber plates

- Moving machines sealed with the shock absorber plates

#### 10.4 Instructions for securing the machine on the ground



#### Caution



Only for machines without weighing equipment.

Place the machine on a perfectly even surface and horizontal.

Control this using a water level (see drawing).

Each point must be level.

#### Note!

On the drawings , H1 and H2 are the position of the drain outlet for the barrier machine depending on the different model. (H1 one drain and H2 the second drain (option))

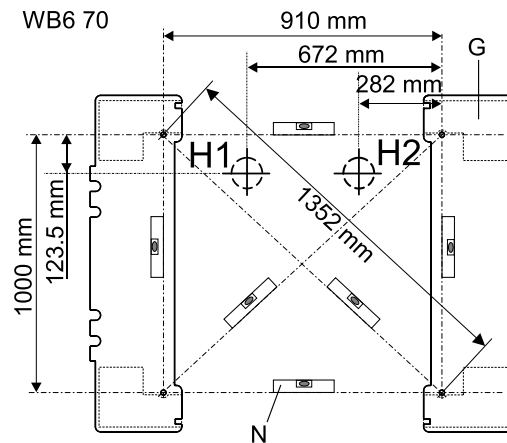
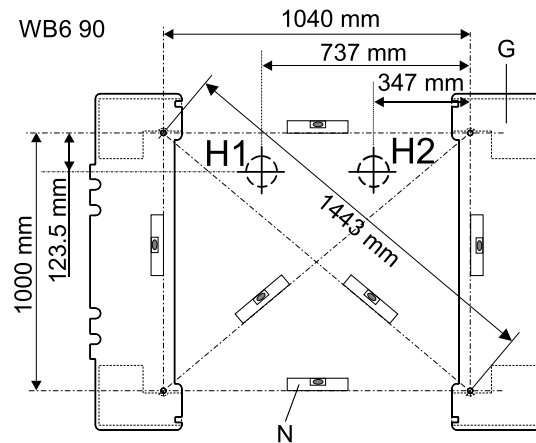
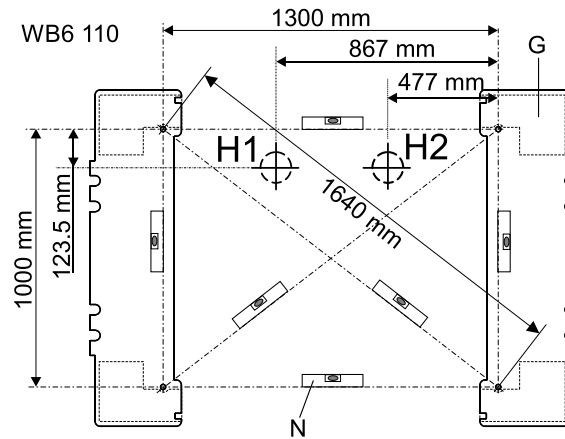

Mark out the drill holes for the securing dowels and drill them so as to insert the 4 dowels , they will secure the machine to the floor.

Put the machine in position and secure it with the dowels without tighten.

Bolsters: G

Water level: N

### 10.5 Setting the shock absorber plates

Place each plate (G) at its respective location (see drawing) and heave successively each bearing of the machine. Verify the levels and place if necessary the wedges (C) between the absorber plate and the soles to stabilize the machine.

When the "trial" stalling is realized, apply obligatory the glue (type SILICOMET) on every plate face and under the soles of the machine (see drawing)

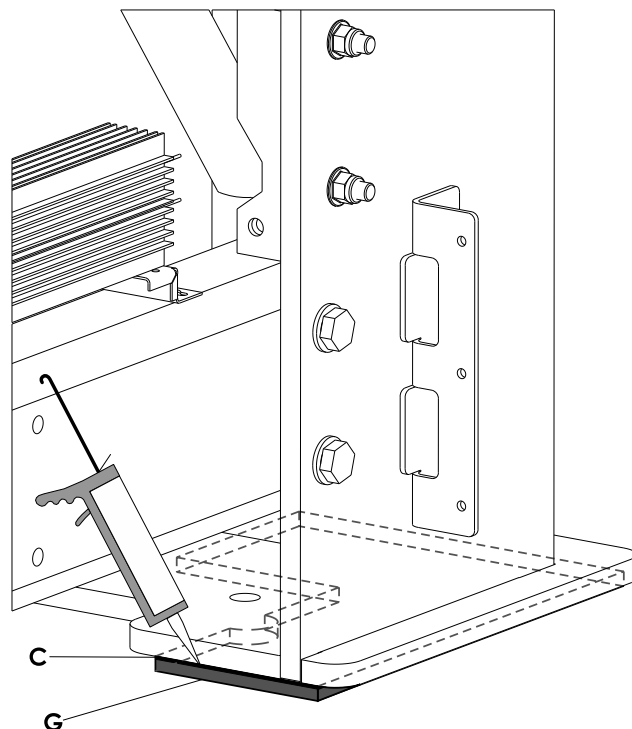

The indicated faces on the drawing must be aligned. Apply equally glue to each face of the used wedges. Put the machine in position and secure it with the bolts (F) **without tighten**.

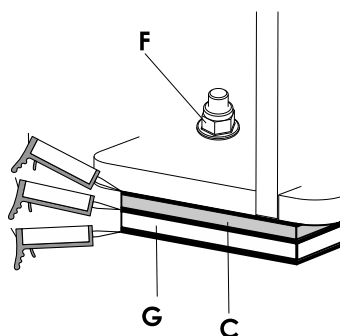

**Electrical safety device** : As rubber is a very good electric insulating material, the earthing of the machine is mandatory.

**To displace the machine sealed with absorber plates**: You must introduce a flat chisel between the ground and the absorbers plates by heaving the machine; you have to remove them and avoid to pull off the ground.

## 11 Remove of the transport locks fitted



### Important



Before putting the machine into service, it is compulsory to remove the 4 transport locks fitted.

To do so, remove the side casings, then the fixing screws of the transport locks (B), as well as the transport lock screws of the down casings (A).

Keep the transport locks fitted with their screws and bolts to be able to assemble them again in case you would need to lift the machine.

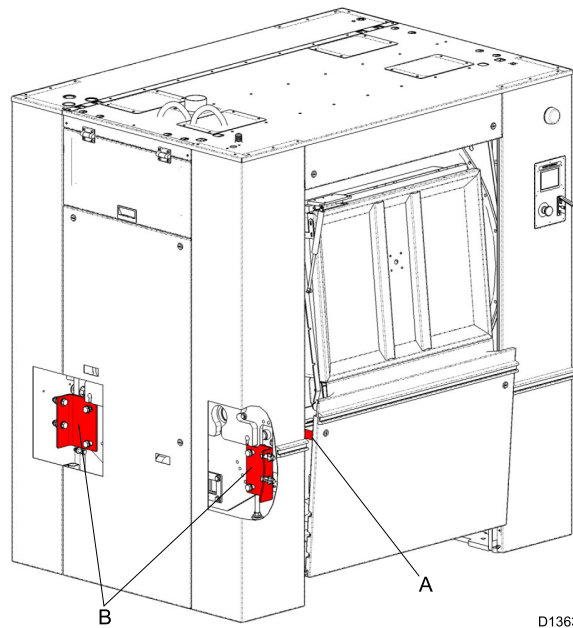

	<b>Important</b>	
Never handling the machine without the transport locks.		

## 12 Barrier partition

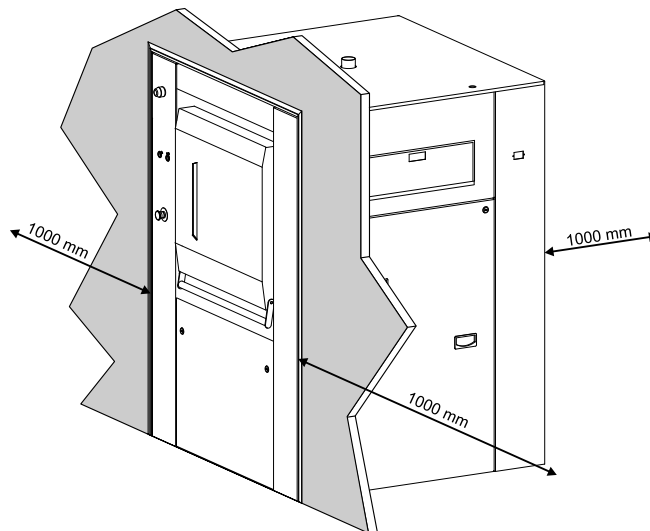

Leave at least 1 m (40") (according to the recommendation in standard EN 60204) between the machine, a wall or any other machine at the sides.

mm/in	A	B	C	D
<b>WB6-70</b>	1570	2080	2040	1490
<b>WB6-90</b>	1800	2080	2040	1720
<b>WB6-110</b>	2030	2080	2040	1950

\* Minimum 70 mm (2.76"),, maximum 100 mm (4"),.

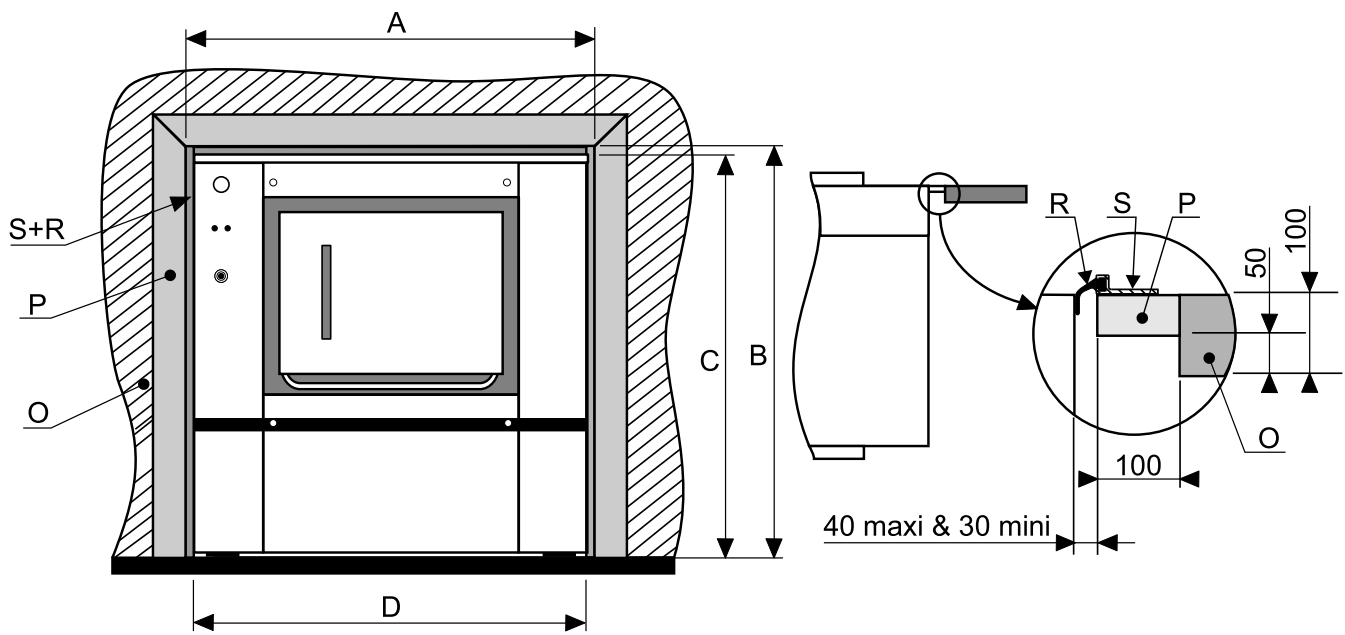

- The barrier partition (O) shall be built before the installation of the machine.
- Centre and align the washer-extractor with the frame (P) 60x100mm (2x4") maximum (provided by customer)..
- Place the rubber seal (R) inside the aluminium extruded section (S).
- Screw the aluminium extruded section (S) on the frame or on the optional plates (P).

Additional angle bar to be placed at the bottom of the machine.

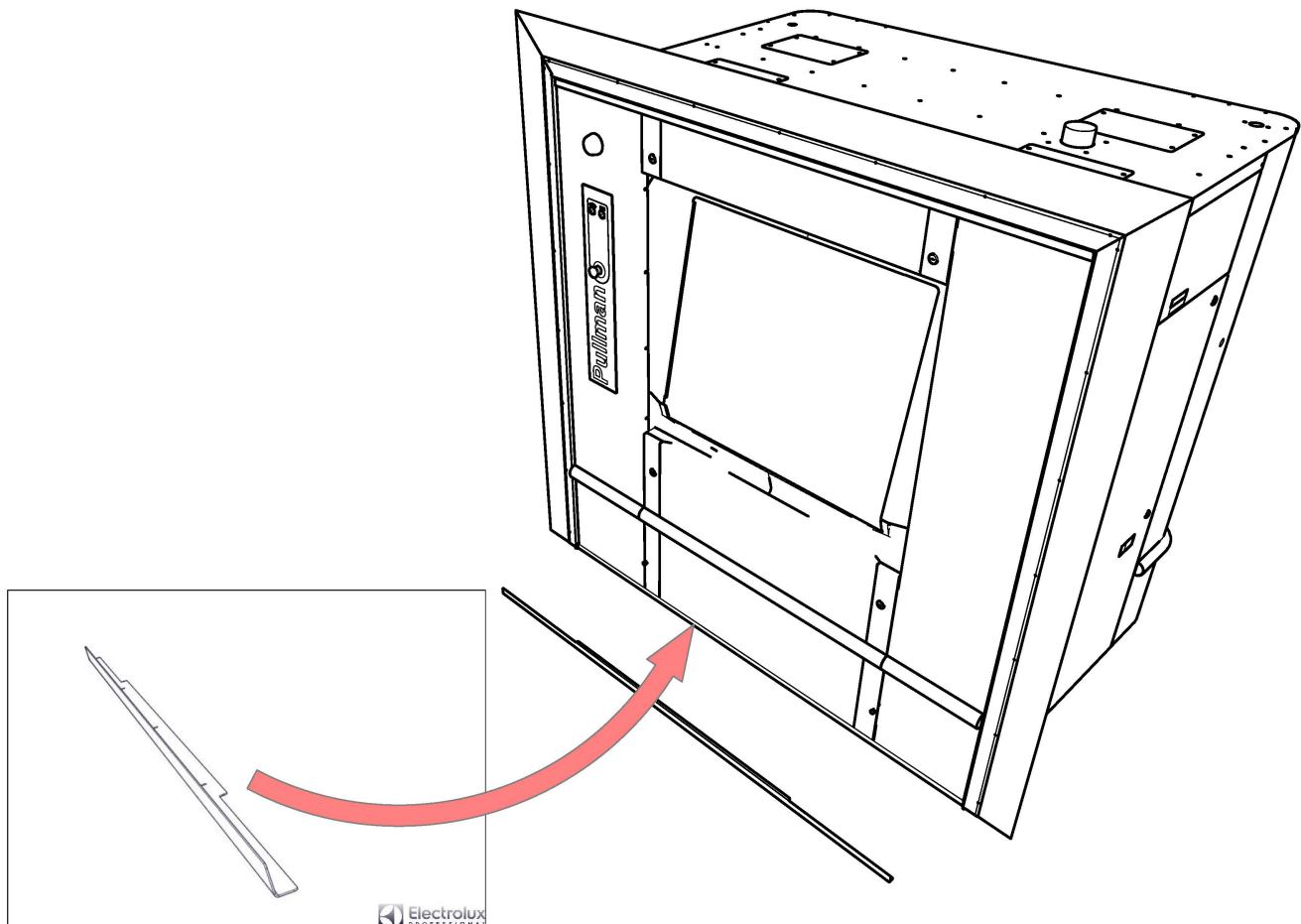



### 13 Drain connection

The machine's exhaust sleeve outside diameter is of 110 mm (4.33"). It is located underneath the machine.

The waste water collector diameter 200 mm (7.87") (manufactured by customer) should have a 3 cm/m (3 %) slope and resist to a temperature of 90 °C (194 °F). It should be connected to the waste water general network in accordance with local codes and regulations.

Adapt and connect the machine's exhaust sleeve to the waste waters' collector (rubber bend and connection nozzle are supplied in the machine with collars).

#### Drawing of drain connection to waste waters' collector

1. Connect the hose (B) to the connect nozzle (C).
2. Seal and fix the nozzle (C) using 2 screws.
3. Then connect the hose (B) to the drain's evacuation sleeve (A).

<b>A</b>	Drain's evacuation sleeve
<b>B</b>	Connection hose
<b>C</b>	Connection nozzle
<b>D</b>	Waste water collector

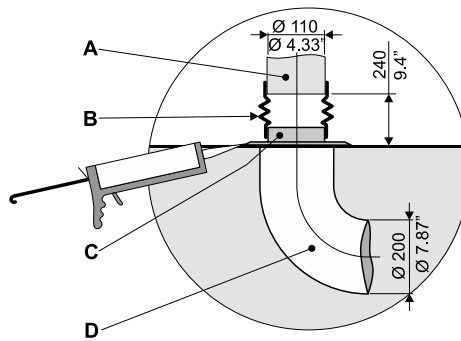

## 14 Waters connections

Washer extractors are assembled in standard execution with two waters inlet.

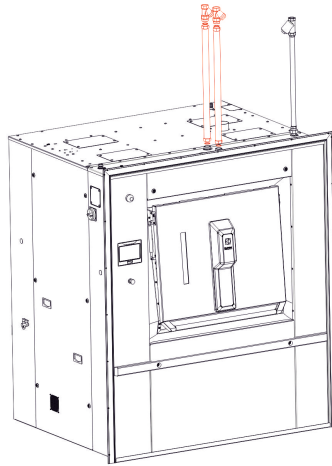

One hot water and one hard water. On option, a third water inlet (soft) is possible.

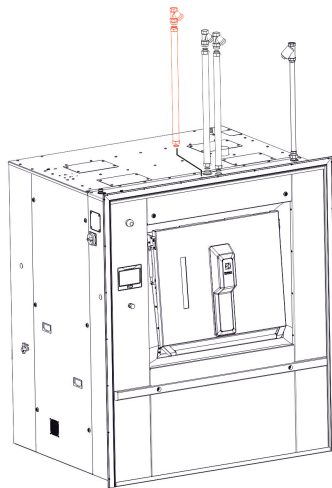

The supply pipes to the machine should be fitted with manual shut-off valves to facilitate installation and service. Fit filters to the manual shut-off valves with Teflon. Refer to local utilities regulations when fitting nonreturn valves. A screen at the entrance to the machine filter should be necessarily mounted, it must have a mesh size of 0.3 mm. Any malfunction of water solenoid or water pneumatic valves due to a absence or a poor maintenance of the filters will not be taken under warranty.



### Caution



It is strictly forbidden to use the electrical control of the third water to drive any equipment. Only the pneumatic outlet can be used.

The following values apply to water pressure:

**Water supply pressure, 50 kPa (7.25 psi) mini.**

**Water supply pressure, 300 kPa (43.5 psi) maxi.**

The hoses should be flushed through before being connected to the machine.

The hereunder example sketch shows the connection of the machine to the different inlets.

- A** Washer-extractor
- E** Hard water inlet DN 32 (1"1/4 BSP female) only this one for Clean Room Option
- D** Hot water inlet DN 32 (1"1/4 BSP female) (T max 60° C)

- F** Cold soft water inlet (option) DN 32 (1"1/4 BSP female)
- U** Manual stop valve DN 32 (1"1/4 BSP) (provided by customer)
- B** Water filter (provided)
- X** Nipple DN 32 (1"1/4 BSP) (provided)
- Y** Flexible pipe DN 32 (1"1/4 BSP) length : 80 cm (provided)

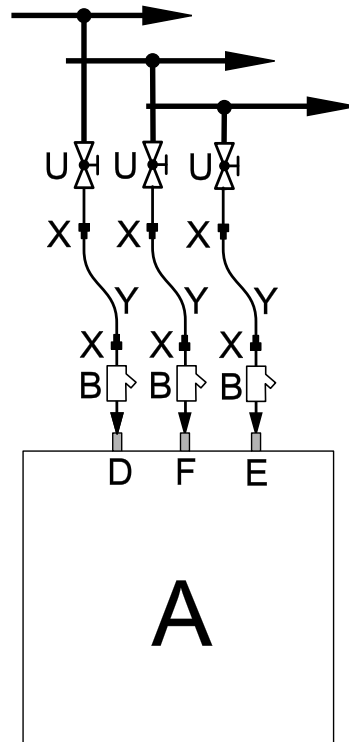

### Adjustment of the water pressure (Kit 56000183)

The factory setting is 3 bar for the pressure.

You must adjust the electrovalves according to the water pressure of your network.

- Unscrew the nut (C) of each electrovalve and screw the screw (B) up to the end,
- For a 1 bar pressure, unscrews the screw (B) of 17 1/3 rounds (26 mm)
- For a 2 bars pressure, unscrews the screw (B) of 4 1/3 rounds (6 mm)
- For a 3 bars pressure, unscrews the screw (B) of 3 1/3 rounds (5 mm)
- For a 4 bars pressure, unscrews the screw (B) of 2 2/3 rounds (4 mm)
- For a 5 bars pressure, unscrews the screw (B) of 2 rounds (3 mm)
- For a 6 bars pressure, unscrews the screw (B) of 1 1/3 rounds (2 mm)
- Screw the nut (C) of each electrovalve.

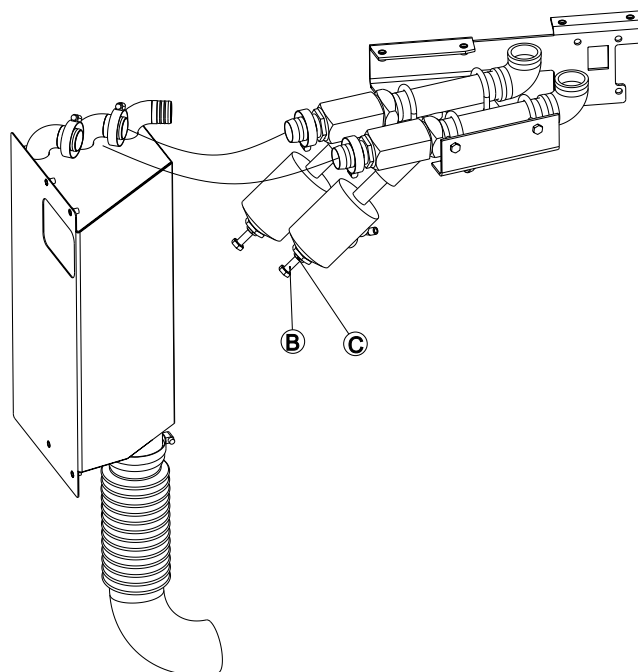

### According to the standard EN1717

The closing sheet (A) is normally mounted on the machine. If not, use the side sheet supplied with the machine (ref. 31105197 or ref. 31105124); this allows to reduce the water filling time.

If you must comply with the standard EN1717, remove this sheet and reduce the water pressure to limit the splashes by the side hole.

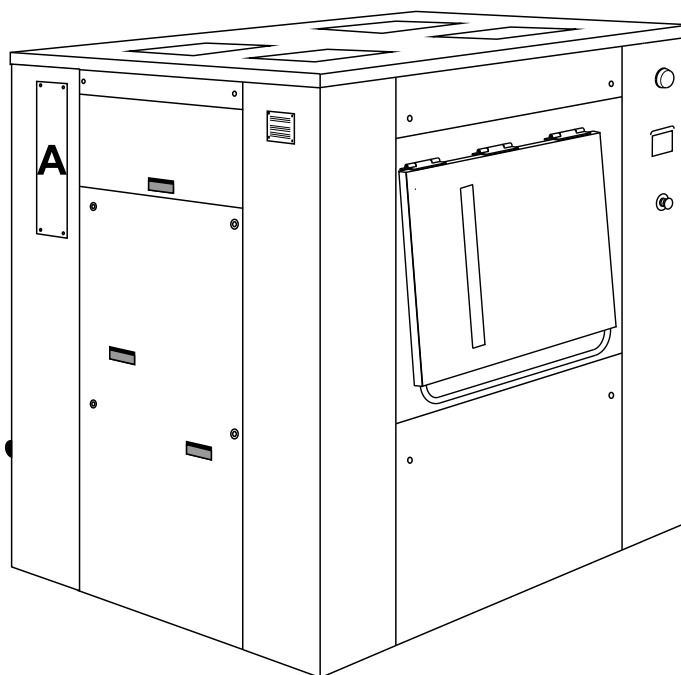

## 15 Liquid detergents connection

The machine is equipped with a connection for the use of external liquid detergents.

If you do not use the detergent box, please use the cap delivered with the machine in order to avoid vapour from steaming out through the opening of the bow downpipe.

Installing :

Open the door of the detergent box . Place the silicone cap in the hole of the bow downpipe.

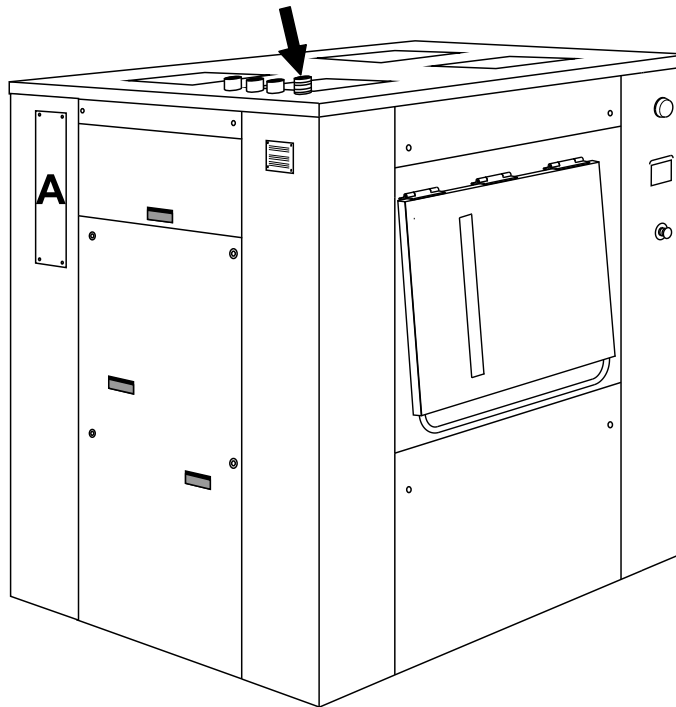

**Caution**



In a view to avoid an overflowing risk, do not forget to remove the silicone cap if you use the detergent box.



**Caution**



Liquid detergents are particularly aggressive.  
We advise you to use only products with pH lower than 9 in order to avoid the machine's rubbers from being attacked.  
Dilute imperatively all of your detergents before letting them flow into the machine.



**ADVISE IF USING LIQUID DETERGENTS**



After use, there is always chemical remaining in the liquid detergents' dosing pipes.  
When the machine is not running, this detergent may slowly drip and so, quickly corrode the parts in contact with.  
In order to avoid (ex. corrosion of the drum or by bleach), we advise you to forecast a device to drain every night the distribution pipes of the liquid detergents.



**Caution**



The running of detergents must be independent from the running of the machine.  
The control information of detergents must imperatively be relayed.  
It is imperative to use armoured wires for every connection in the electrical box.

### 15.1 Connection scheme of liquid detergents

We advise you to use one of the two systems shown hereby to connect your liquid detergents.  
Single inlet dose controller with a compulsory rinsing device.

1	Retention tank	7	3 way valve
2	Pump	8	Scoops + Rinsing
3	Liquid detergents	9	Water
4	Water	10	Washer extractor
5	Soap box rinsing electrovalve	11	Toward retention tank
6	Dose controller	12	Retention tank

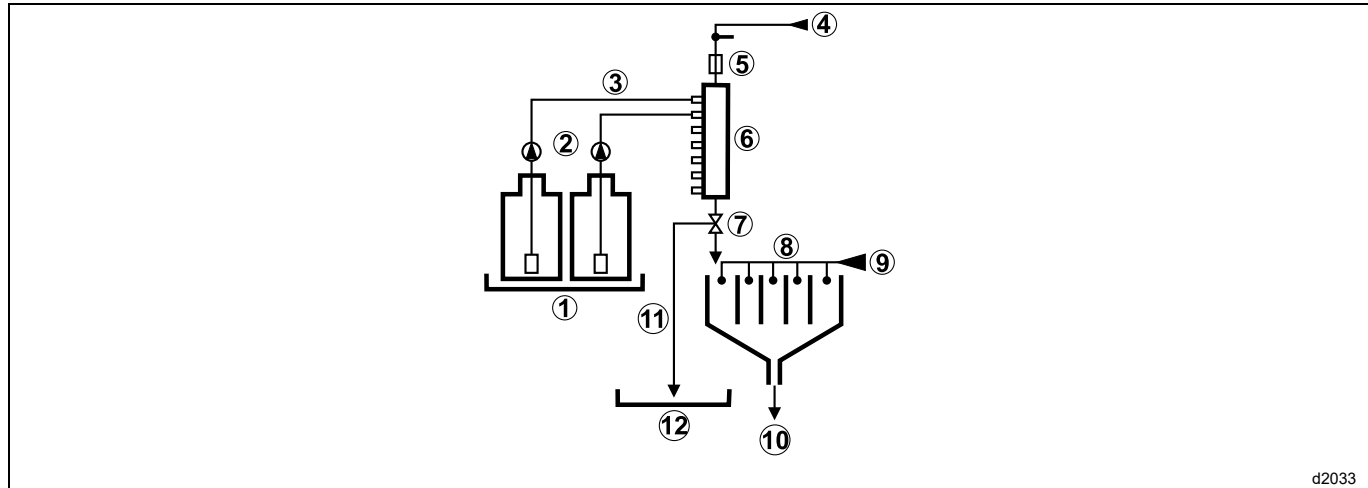

Multi-inlet dose controller with a compulsory rinsing device.

1	Retention tank	7	3 way valve
2	Pump	8	Scoops + Rinsing
3	Liquid detergents	9	Water
4	Water	10	Washer extractor
5	Soap box rinsing electrovalve	11	Toward retention tank
6	Dose controller	12	Retention tank

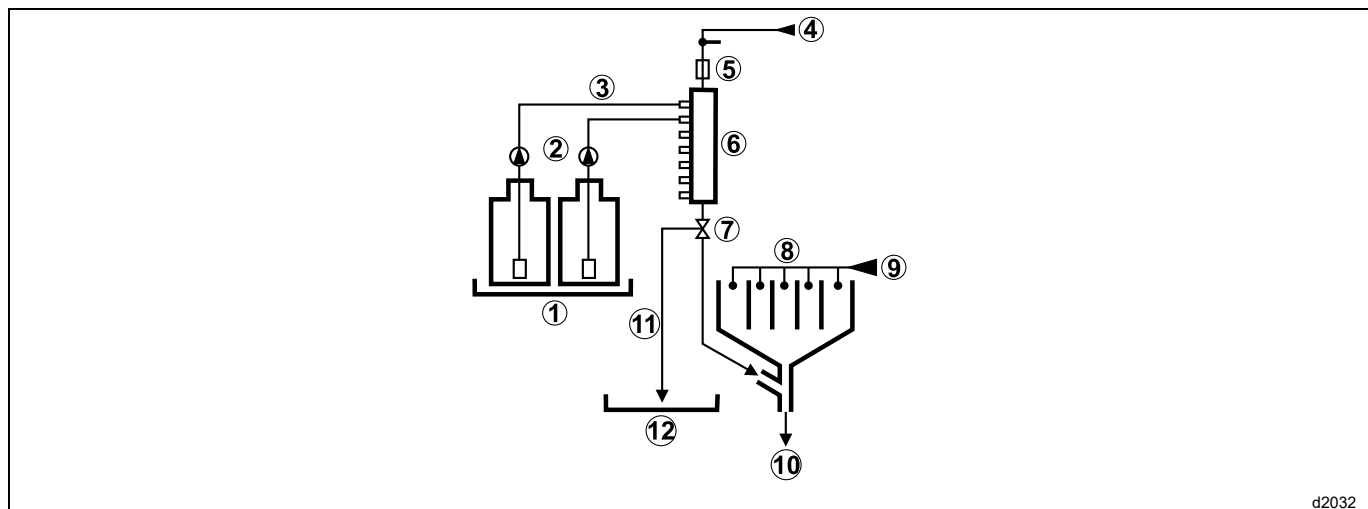

## 15.2 Electrical liquid detergents' connection



Electrical installation must be carried out by an authorized personnel.



The two IO22 cards allows to connect from 1 to 16 electrovalves of liquid detergents.  
The cards are situated on the middle of the electric box.

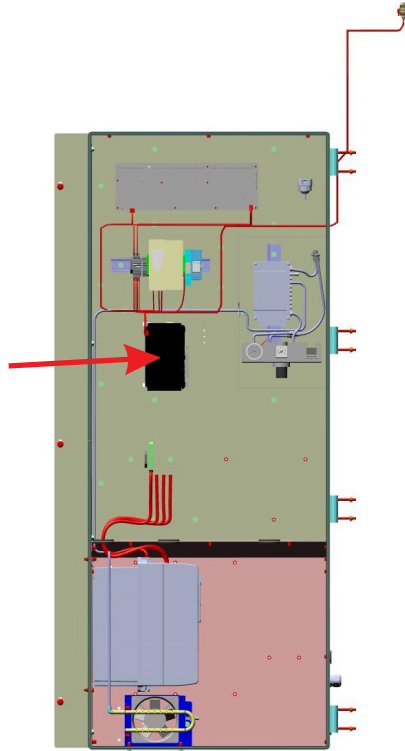

Carry the connection cables by the partition crossing and the cable through of the machine.



### Caution



Be carefull, even machine power off, you can still have power on this board coming from detergent supplier.  
Secure it also before intervention.

#### Connection on the detergent IO22 card

Please refer to the electric schematics to see how is connected the different detergent on these two IO card !

Supply voltage : 250 V~ maximum

Maximum intensity : 6 A.

## 16 Steam connection

For transport reasons, the steam electrovalve is dismantled and placed in the cardboard box supplies.

The inlet pipe to the machine has to be fit with a manual stopping valve to ease installation and maintenance and a flexible steam supply pipe to allow reliable running of automatic weighing system.

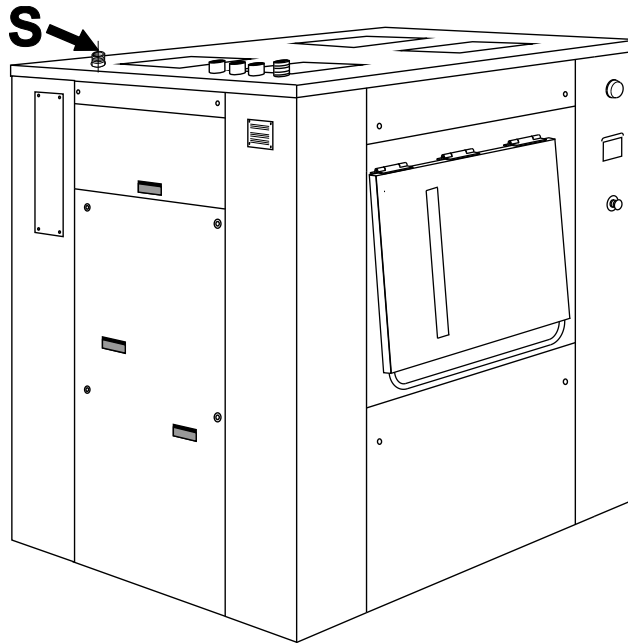

Hereunder values apply to the steam pressure:

**Recommended pressure: 300 at 600 kPa (3 at 6 kg/cm<sup>2</sup>) (43.5 at 87 psi)**

**Limiting of values:**

- **mini. 100 kPa (1 kg/cm<sup>2</sup>) (14.5 psi)**
- **maxi. 600 kPa (6 kg/cm<sup>2</sup>) (87psi)**

Connection size: DN 25 (1" BSP male).

Connect the steam installation on the top of the machine (see example sketch).

<b>A</b>	Washer-extractor
<b>S</b>	Steam inlet
<b>Y</b>	Manual stop wheel valve DN 25 (1" BSP) (provided by customer)
<b>P</b>	Steam filter DN 25 (1" BSP) (provided)
<b>F</b>	Steam special flexible pipe DN 25 (1" BSP) (provided) length : 70 cm
<b>U</b>	Pipe union DN 25 male/female (1" BSP) (provided)

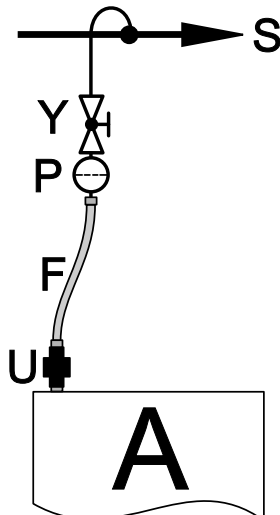



**Steam connection low pressure**

Hereunder values apply to the steam pressure:

**Recommended pressure: 250 kPa (0.5 kg/cm<sup>2</sup>) (36 psi)**

Connection size: DN 32 (1"1/4 BSP male).

Connect the steam installation on the top of the machine (see example sketch).

- A Washer-extractor
- S Steam inlet
- Y Manual stop wheel valve DN 32 (1"1/4 BSP) (provided by customer)
- P Steam filter DN 32 (1"1/4 BSP) (provided)
- F Steam special flexible pipe DN 32 (1"1/4 BSP) (provided) length : 70 cm
- U Pipe union DN 32 male/female (1"1/4 BSP) (provided)

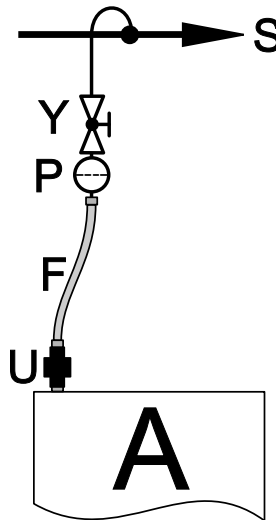

**17 Air vent connection**

The air vent of the outer drum opens on the top of the machine. Connect the bent hose to this opening.

Connect the air vent, to the outside of the laundry in accordance with the legislation.

The air vent should resist to 100 °C (212 °F) temperature and allow the condensates to return to the machine.

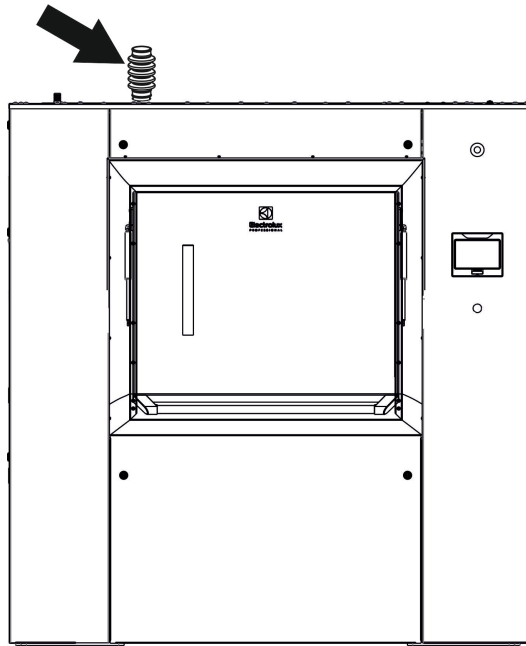

**17.1 Air vent connection for clean room installation**

The air vent of the outer drum opens on the top of the machines. You may connect according to one of the 2 alternatives we recommend below.

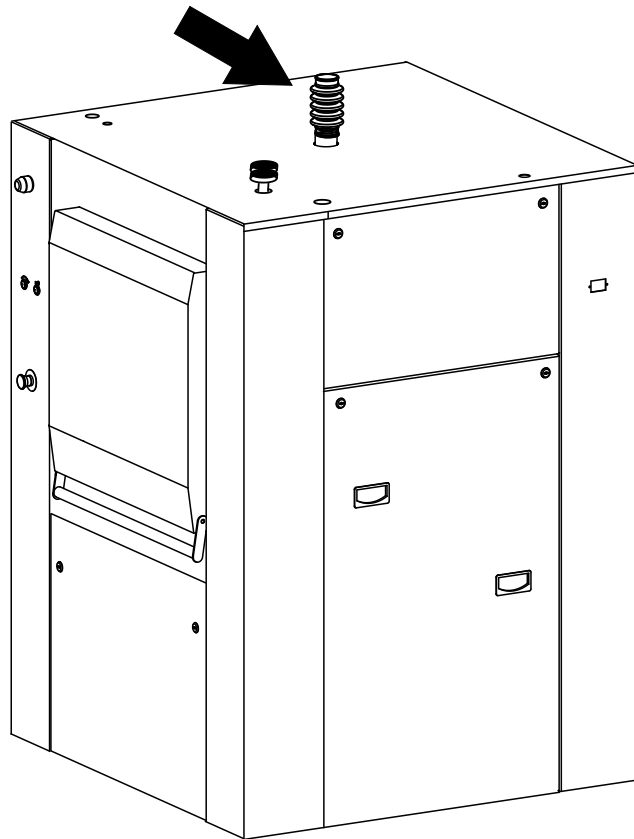

It is important that the machine is put at atmospheric pressure as the levelling of water depends on it.

**Alternative 1 :**

Pressurized HEPA (High Efficiency Particulate Air) filtered air

When the machine drains water, clean air must go in

When the machine fills with water, dirty air goes out and must be pushed away by HEPA filtered air

Exhaust clean and dirty air into a grey room

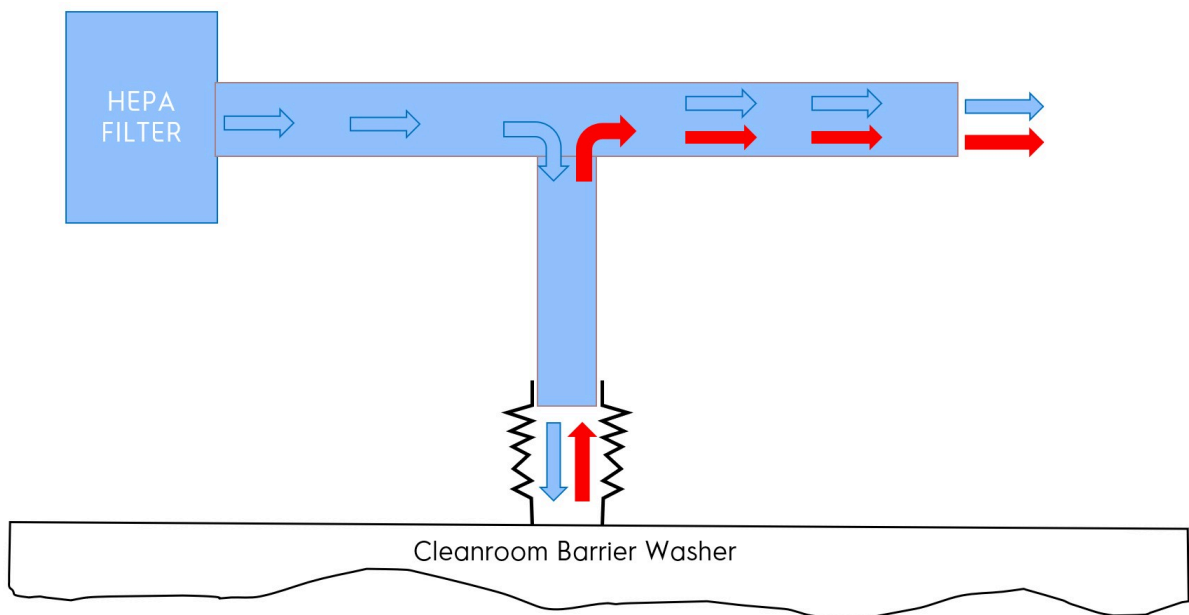

**Alternative 2 :**

When the machine drains water, clean air must go in

When the machine fills with water, dirty air goes out and must be trapped in the HEPA filter.

The type of HEPA to be used must be so that it works both ways and traps the particles inside. It must not release the particles when the machine drains water.

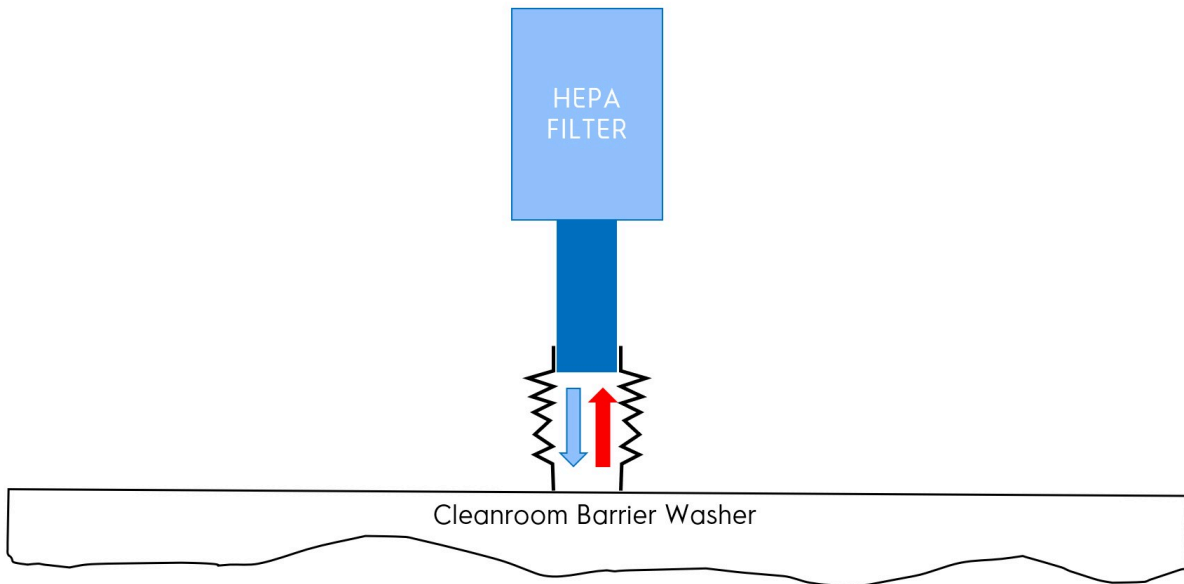

## 18 Note about the A.C. power

According to the EN 60204-1:2018 standard, the machine is provided for A.C. supplies corresponding to the extracted characteristics below :

### 4.3.2 A.C. supplies

#### **Voltage:**

Steady state voltage: from 0.9 to 1.1 of nominal voltage.

#### **Frequency:**

from 0.99 to 1.01 of nominal frequency continuously.

from 0.98 to 1.02 short time.

#### **Harmonics:**

Harmonic distortion not to exceed 10 % of the total r.m.s. voltage between live conductors for the sum of the second through to the fifth harmonic. An additional 2 % of the total r.m.s. voltage between live conductors for the sum of the sixth through to the 30th harmonic is permissible.

#### **Voltage unbalance:**

Neither the voltage of the negative sequence component nor the voltage of the zero sequence component in three-phase supplies shall exceed 2 % of the positive sequence component.

#### **Voltage interruption:**

Supply interrupted or at zero voltage for not more than 3 ms at any random time in the supply cycle. There shall be more than 1 second between successive interruptions.

#### **Voltage dips:**

Voltage dips shall not exceed 20 % of the peak voltage of the supply for more than one cycle. There shall be more than 1 second between successive dips.

## 19 Feeder cable sections

The feeder cable sections mentioned in our literature are given only as a guide.

To obtain a value perfectly suited to your own application and which takes account of the different correction factors in respect of your plant, refer to the tables below.

**Table 1 (in accordance with EN Standard 60204-1)**

Values given for:

- Cable with copper conductors
- Cable with PVC insulation (for other insulants see Table 3)
- Ambient temperature 40°C max. (for others see Table 2)
- Three-phase cable under load without including starting currents
- BT / C/ E cable layout.

### Maximum Admissible Current

Cable section	Seated in Cable Duct or Cable trough	Wall fixing	Cable tray
	B2	BC	E
3 x 1.5 mm <sup>2</sup>	12.2 A	15.2 A	16.1 A
3 x 2.5 mm <sup>2</sup>	16.5 A	21 A	22 A
3 x 4mm <sup>2</sup>	23 A	28 A	30 A
3 x 6 mm <sup>2</sup>	29 A	36 A	37 A
3 x 10 mm <sup>2</sup>	40 A	50 A	52 A
3 x 16 mm <sup>2</sup>	53 A	66 A	70 A
3 x 25 mm <sup>2</sup>	67 A	84 A	88 A
3 x 35 mm <sup>2</sup>	83 A	104 A	114
3 x 50 mm <sup>2</sup>	-	123 A	123 A
3 x 70 mm <sup>2</sup>	-	155 A	155 A

**Table 2 (correction factors for different ambient temperatures)**

Ambient temperature	Correction factor
30 °C	1.15

35 °C	1.08
40 °C	1.00
45 °C	0.91
50 °C	0.82
55 °C	0.71
60 °C	0.58

**Table 3 (correction factors for different cable insulating materials)**

<b>Insulating material</b>	<b>Max. Working temperature range</b>	<b>Correction factor</b>
<b>PVC</b>	70°C (158 °F)	1.00
<b>Natural or Synthetic Rubber</b>	76°C (140 °F)	0.92
<b>Silicone Rubber</b>	120°C (248 °F)	1.60

Table 4 (B2, C and correction factors for cable grouping)

Number of cables	B2	E	E
	Seated in Cable Duct	Wall fixing or Cable trough	Cable tray
1	1.00	1.00	1.00
2	0.80	0.85	0.87
4	0.65	0.75	0.78
6	0.57	0.72	0.75
9	0.50	0.70	0.73

The total current included for using Table 1 should be the maximum rated current for the machine divided by the product of the different correction factors. Other correction factors may also be applied ; consult the cable manufacturers.

Calculation : Example

- The machine has a rated current of 60 A.
- The ambient temperature is 45 °C ; Table 2 gives a correction factor of 0.91.
- Rubber cable insulant : Table 3 gives a correction factor of 0.92.
- The cable is fixed directly to the wall (Column C), with 2 cables side by side. Table 4 gives a correction factor of 0.85.

$$\text{Total current : } \frac{60 \text{ A}}{0.91 \times 0.92 \times 0.85} = 84 \text{ A}$$

Taking Column C in Table 1 (wall fixing), we obtain a minimum cable section of : 3 x 25 mm<sup>2</sup>.

## 20 Electricity power supply



Prior to use, the washer-extractor should be connected to a multi-pole switch prior to the machine to facilitate installation and service operations.



### Caution



The electrical installation of the machine must be undertaken by qualified personnel.



### Caution



Ensure that the electrical voltage is correct and that the power of your supply is sufficient, before connecting the machine.



### Caution



The main switch is located on the right side of the machine , identified by this sticker.



**Note!**

The use of power electronics (converter or filter for example) may lead to unexpected release of breakers with 30 mA differential current device.

Therefore a Type B residual differential protection system with reinforced immunity of 300 mA in accordance with standard NFC 15100 must be used for our washing machines.

To avoid these untimely activations, you ought to use differential protecting systems with residual current only, having a high level of reinforced immunity as regards leakage transient current.

Pass the power supply cable of the machine through the stuffing box on the top of the machine.

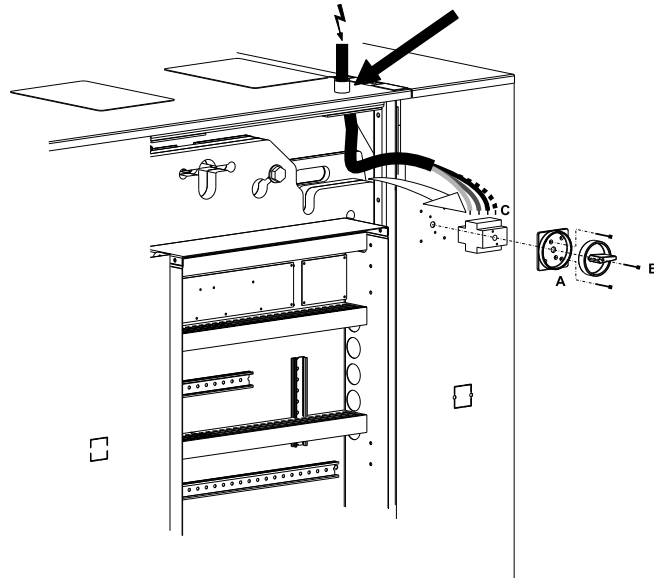

### Caution



The main switch must be removed in order to have easy access to the connections terminals. Remove the outer sections (A) and the inner section (C) by unscrewing the screws (B). When the cables are attached, reassemble the switch in reverse order.

For each machine, install a fixed multipolar circuit breaker (or fuses protector) in the laundry main cabinet.

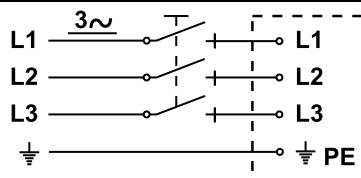

d0466

Connect the power supply cable on the machine main switch. Connect the 3 phases on the main switch (see marks L1, L2, L3) and connect the earth wire on the earth terminal (PE) of this main switch. (see chapter "Function checks").





**Caution**



In case of a machine with integrated weighing, you must use a flexible power supply cable to connect the machine.

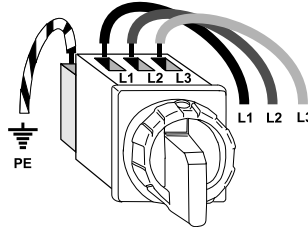

Machine type	Heating	Supply Voltage	Rated Power	Rated Intensity	Connection cable section	Protection
70	Electric	400 V / 3 / 50–60 Hz	65.7 kW	100.5 A	4 x 35 mm <sup>2</sup> / AWG 2	3 x 125 A
	Electric/Steam	400 V / 3 / 50–60 Hz 480V 3+E ~ 50/60 Hz	65.7 kW 67.7 kW	100.5 A 80 A	4 x 35 mm <sup>2</sup> / AWG 2	3 x 125 A 3 x 100 A
	Steam	200 V / 3 / 50–60 Hz 208–240 V / 3 / 50–60 Hz 400 V / 3 / 50–60 Hz	11.7 kW	27 A	4 x 10 mm <sup>2</sup> / AWG 8	3 x 50 A 3 x 50 A 3 x 32 A
90	Electric	400 V / 3 / 50–60 Hz	87.7kW	135 A	4 x 35 mm <sup>2</sup> / AWG 2	3 x 160 A
	Electric/Steam	400 V / 3 / 50–60 Hz 480V 3+E ~ 50/60 Hz	87.7 kW	135 A 105 A	4 x 50 mm <sup>2</sup> / AWG 2	3 x 160 A 3 x 125 A
	Steam	200 V / 3 / 50–60 Hz 208–240 V / 3 / 50–60 Hz 400 V / 3 / 50–60 Hz	15.7 kW	33 A	4 x 10 mm <sup>2</sup> / AWG 8	3 x 63 A 3 x 63 A 3 x 40 A
110	Electric	400 V / 3 / 50–60 Hz	91 kW	140 A	4 x 50 mm <sup>2</sup> / AWG 1	3 x 160 A
	Electric/Steam	400 V / 3 / 50–60 Hz 480V 3+E ~ 50/60 Hz	91 kW	140 a 110 A	4 x 50 mm <sup>2</sup> / AWG 1	3 x 160 A 3 x 125 A
	Steam	200 V / 3 / 50–60 Hz 208–240 V / 3 / 50–60 Hz 400 V / 3 / 50–60 Hz	19 kW	42 A	4 x 10 mm <sup>2</sup> / AWG 8	3 x 80 A 3 x 80 A 3 x 50 A

## 21 Compressed air connection

The customer should arrange the installation of filter device, as well as a pressure regulator (manometer) on the machine's compressed air supply.



**Caution**



The machine must be supplied with dried and perfectly filtered compressed air :  
 The compressed air admitted to the distributors and jacks must be purified to the following values:

- it must be free from solid particles larger than 5 µm. The filter present on our machines has a filtration of 5µm.
- It should not contain more than 1.5 g of water / m3
- It should not contain more than 5 mg of oil condensate / m3

The manual stopping valve lockable in closed position (provided by customer) should be installed on the machine's compressed air supply.

The supply pipe should accept a pressure of at least 1 Mpa (10 bar) (145 psi).

- Connection diameter: rapid action hose coupling DN 6 (0.24") for hose Ø 6/8 mm.
- Advised pressure: 550-700 kPa (5,5-7 bar) (80-102 psi).
- Minimum pressure: 550 kPa (5,5 bar) (80 psi).
- Maximum pressure: 700 kPa (7 bar) (102 psi).

- Consumption 50 l/h.



### Important



To avoid too big head losses, the compressed air supply pipe should be bigger in diameter than the coupling diameter (DN 8 for example); in this case, put a 6/8-8/10 adapter.

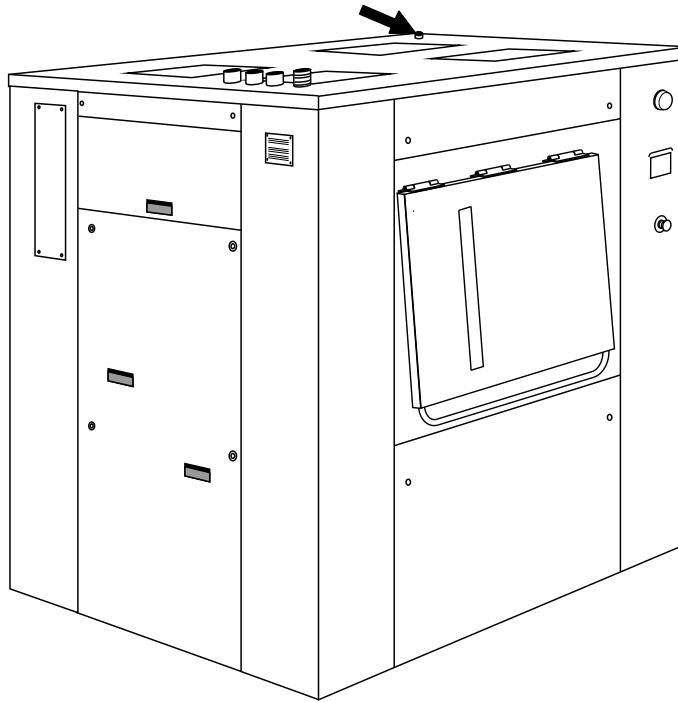

## 21.1 Compressed air standard ISO 8573–1

This chapter explains the required by our product for the air compressed quality, from the standard EN ISO 8573-1. This standard shows the quality of the compressed depending on the particles inside it, the tolerance of these particles give a classification of the required compressed air for our product.

Show in the table below the classification :

ISO 8573–1:2010	First Digit			Second Digit			Third Digit
	Solid particles			Water			Oil
	Max.number of particles per m3			Mass concentration	pressure dew point	Liquid	Total oil content (liquid, aerosol and vapour)
	0.1 ... 0.5 µm	0.5... 1 µm	1 ... 5 µm	mg/m3	°C	g/m3	mg/m3
<b>0</b>	In accordance with specifications by device user, stricter requirements than Class 1						
<b>1</b>	< 20,000	< 400	< 10	-	< -70	-	0.01
<b>2</b>	< 400,000	< 6,000	< 100	-	< -40	-	0.1
<b>3</b>	-	< 90,000	< 1,000	-	< -20	-	1
<b>4</b>	-	-	< 10,000	-	< +3	-	5
<b>5</b>	-	-	< 100,000	-	< +7	-	-
<b>6</b>	-	-	-	< 5	< +10	-	-
<b>7</b>	-	-	-	5 ... 10	-	< 0.5	-
<b>8</b>	-	-	-	-	-	0.5 .. 5	-
<b>9</b>	-	-	-	-	-	5 ... 10	-
<b>X</b>	-	-	-	> 10	-	> 10	> 10

So, the customer should arrange the installation of filter device, as well as a pressure regulator (manometer) on the machine's compressed air supply.



### Important



To ensure the proper functioning of pneumatic devices (cylinders, distributors, clamps, silencers) of our products, the following air quality is recommended:

Particles = class **7**

Water = class **4**

Oil = class **4**

Recommended air quality class **[7;4;4]**, this means that:

For dust, we tolerate between 5 and 10 mg of dust per cubic meter of compressed air.

For water, we tolerate a dew point which does not exceed 3°C

For oil, the presence of 5 mg of oil per cubic meter of compressed air is tolerated

## 22 Connectivity of the barrier washer



### Caution



Every barrier washer L6000 can be connectable to keep some datas of the production made by this product.

Either the machine comes with the connectivity kit or you can order it to make your barrier washer connected.

#### **INSTALLATION INSTRUCTION OF THE CONNECTIVITY BOARD ON THE BARRIER WASHER L6000 range:**

For the installation procedure see instruction **438907725** but it boils down to this:

For type L6000 Barrier washer , the cable supplied with kit 988807401 is used to connect the connectivity board to the machine. The connectivity board is located on the top of the barrier washer as mentioned in the instruction !

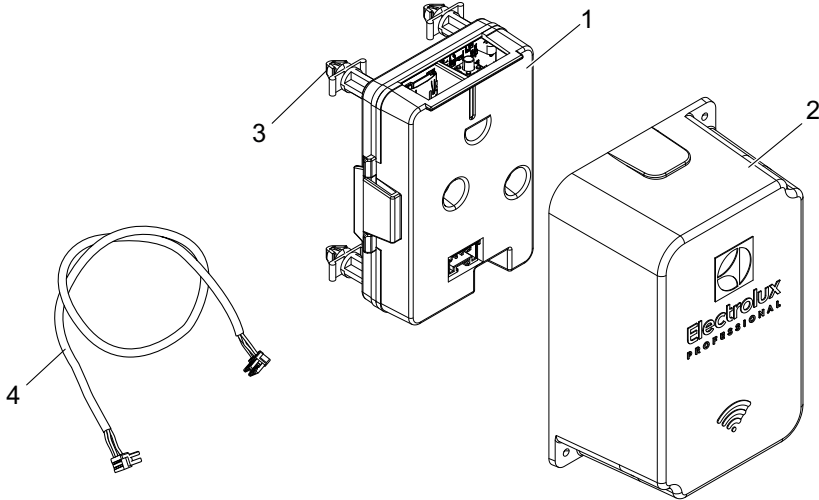

1	432689401	Machine Wireless Board x 1
2	490624901	Machine Wireless Board cover x 1
3	471796002	Circuit support x 4
4	413327505	Harness RS232 Fuse IOT x 1

#### **NETWORK OVERVIEW :**

To be able to use Electrolux Professional provided Connectivity and Management Software Tools, ELS network should be established.

The Machine wireless board is a part of ELS Network, it should be installed on each machine with Compass Pro or Clarus Vibe control system and it be connected to the CPU RS232 port via a quick connection port behind or on top of the machine.

The Site wireless board is designed to be connected to PoE (Power over Ethernet according to IEEE 802.3at) port on the ethernet router otherwise a power supply (D) connected via USB type C with output 5V DC / 8A Max. is required to be connected to the Site wireless board if there is no power supply over ethernet cable.

Network details:

- Machine wireless board on each machine (B)
- Site wireless board (C)
- Power supply, output: USB type C 5 VDC / 8A Max. (option) (D)
- Router with PoE (Power over Ethernet according to IEEE 802.3at) (E)
- Client/remote PC (F)
- Web application & Mobile application (G)

Schematic diagram below also valid for L6000 barrier washer range:

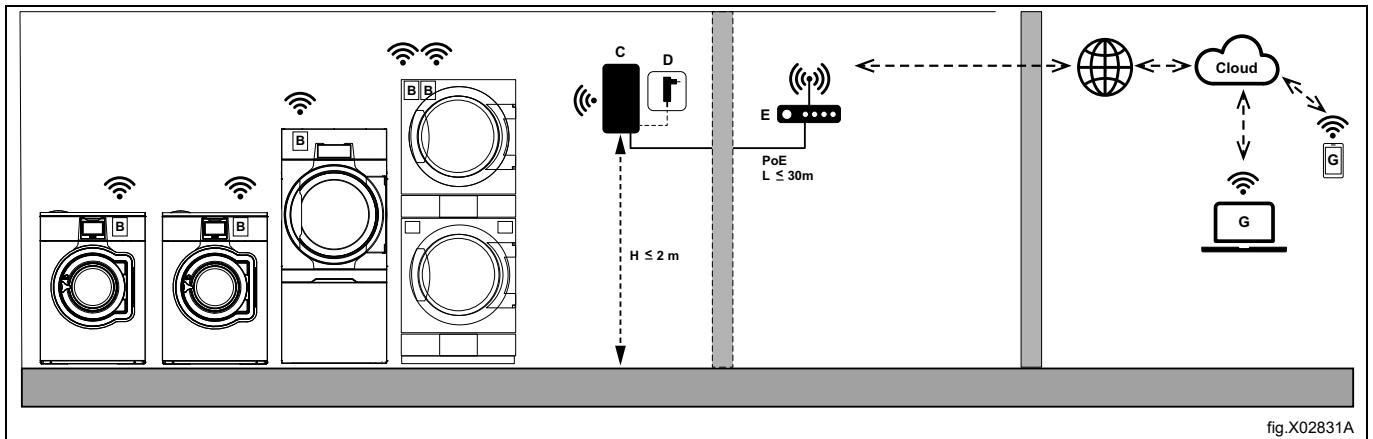

## 22.1 Process to follow with a pre equipped washer machine

Barrier washing machine:

Installing the kit on a pre-equipped barrier washing machine.

The connectivity box must be installed on the upper part of the machine on the water inlet side (on a small cap) as shown in the instruction **438907725**

To do this, follow the following procedure:

1/ Remove the 4 yellow self-adhesive pads for fixing the box.

2/ The connection cable (red) is located under a grommet, remove it and pull the RS232 connection cable held by a label, Be careful not to drop it in the machine! (example below for a Pullman machine, do the same for Evolution or Hyvolution L6000)

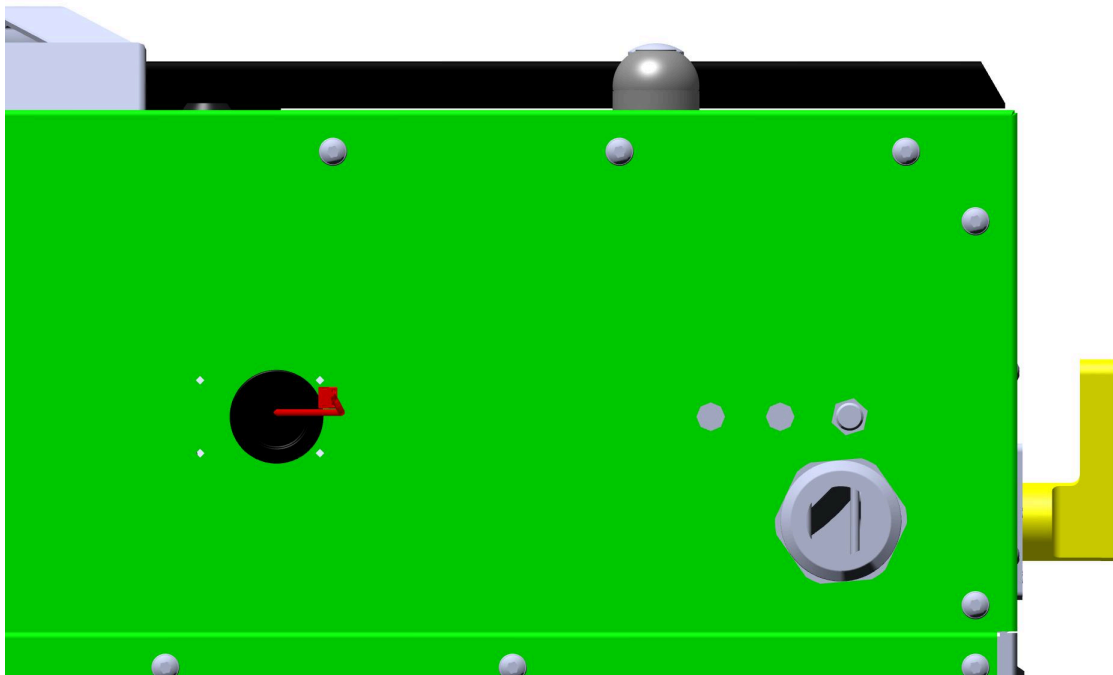

3/ Connect the cable to the machine wireless board,

4/ and clip the board into the 4 fixing holes with the 4 circuit support.

5/ Place the cover.

The machine is now connectable.

## 22.2 Connectivity of the barrier washer with after sales kit

### 22.2.1 Contents of the kit

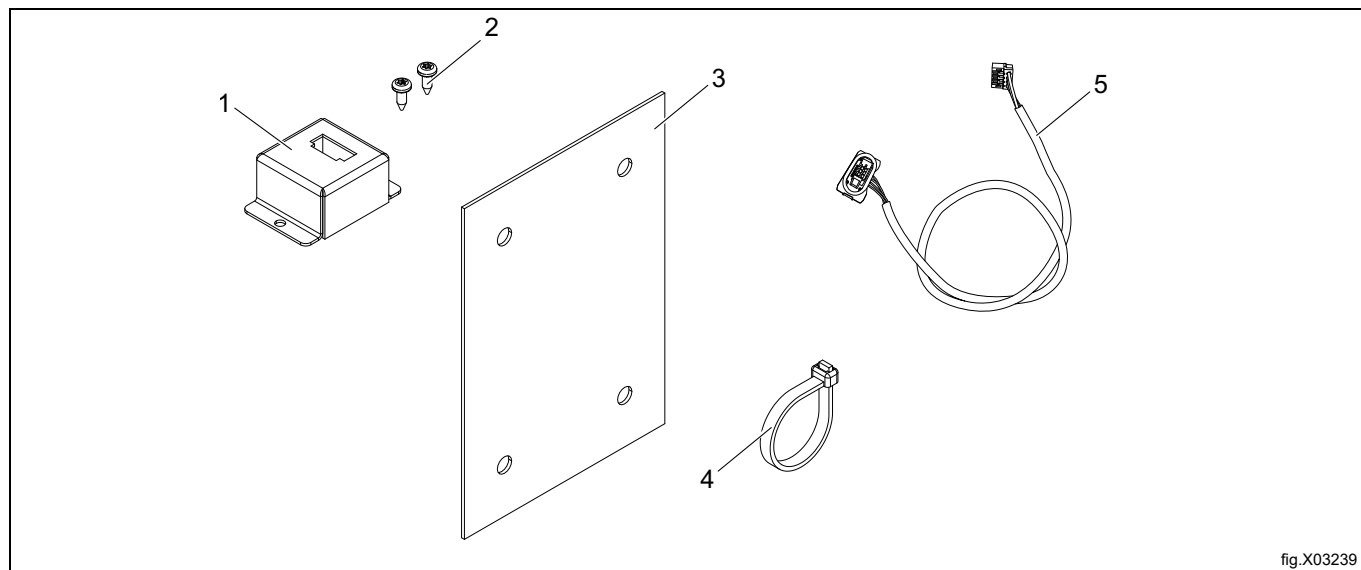

fig.X03239

1	490625001	Plate adapter x 1
2	471836901	Screw M4x11 x 2
3	490625501	Drilling fixture (paper) x 1
4	762910205	Cable tie x 4
5	413327497	Harness RS232 Machine to IOT x 1

### 22.2.2 Required tools

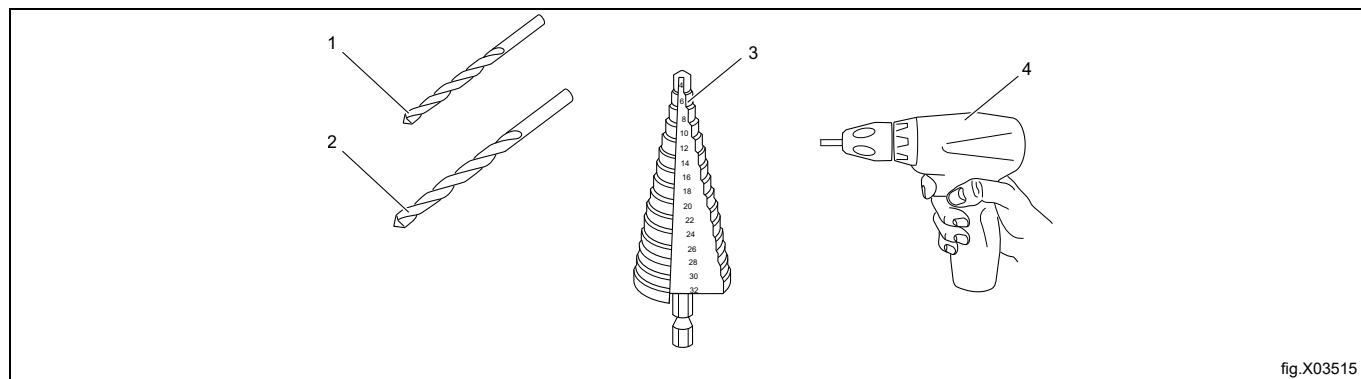

fig.X03515

1	Drill bit $\varnothing$ 3–3.5 mm
2	Drill bit $\varnothing$ 5 mm
3	Step drill bit or drill bit $\varnothing$ 18 mm
4	Drill driver or electric screw driver

**22.2.3 Procedure to follow to connect the barrier washer with after sales kit**

	<b>Caution</b>	
Every barrier washer L6000 can be connectable to keep some datas of the production made by this product.		

Either the machine comes with the connectivity kit or you can order it to make your barrier washer connected.

**Process to install connectivity kit:**

	<b>Caution</b>	
The pictures of this procedure show a <b>WB6 Evolution</b> with Compass Pro, it's the same for the <b>WB6 Hyvolution</b> with Compass Pro and also <b>Hyvolution G5000</b>		

**STEP 1 :** Remove the small and large upper casings from the machine by unscrewing all the screws. (Fig.1)

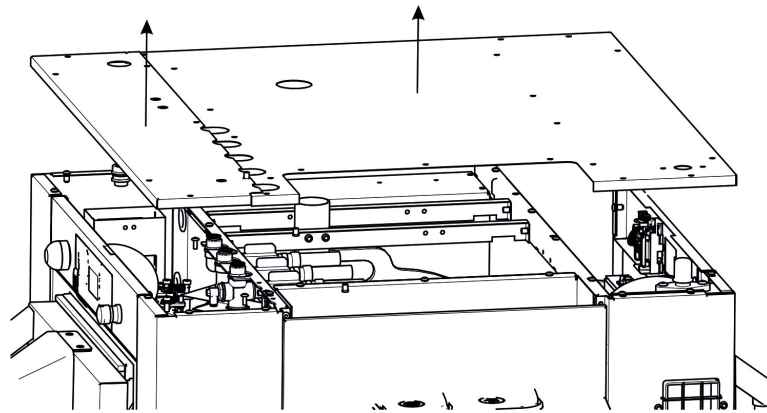

**STEP 2 :** Using the drilling template, drill the small cap with 4 holes provided for installing the connectivity card (Fig.2)

4 holes with the Drilling fixture (paper) with 5 mm drill bit.

and then drill another hole in the center of the previous 4 with an 18 mm drill bit, to allow the cable to pass through.

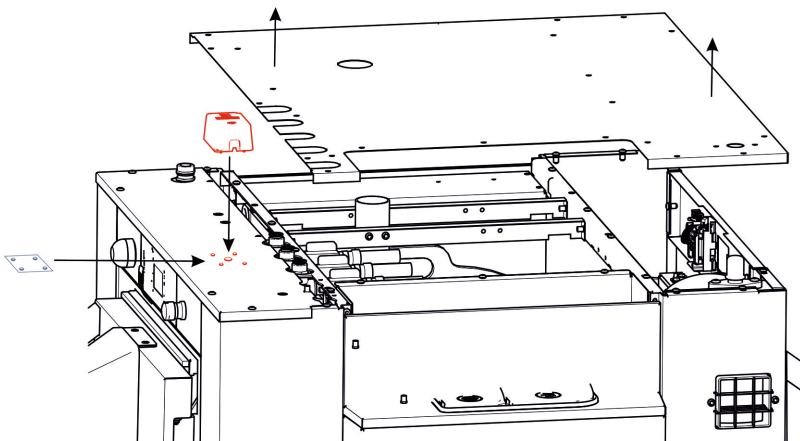

**STEP 3 :** Pass the cable and attach it to the various bodywork elements. (Fig.3 & Fig.4)

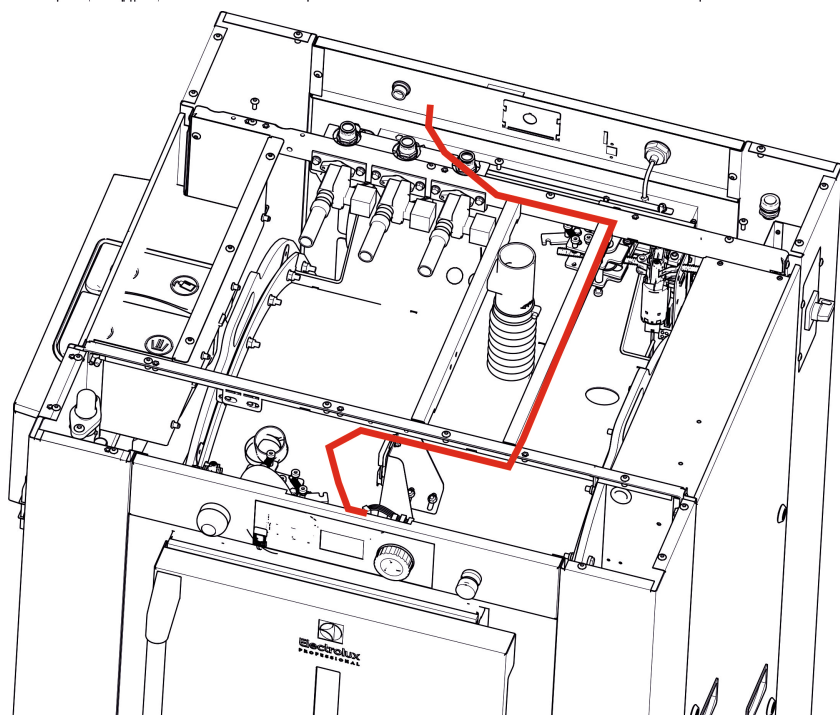
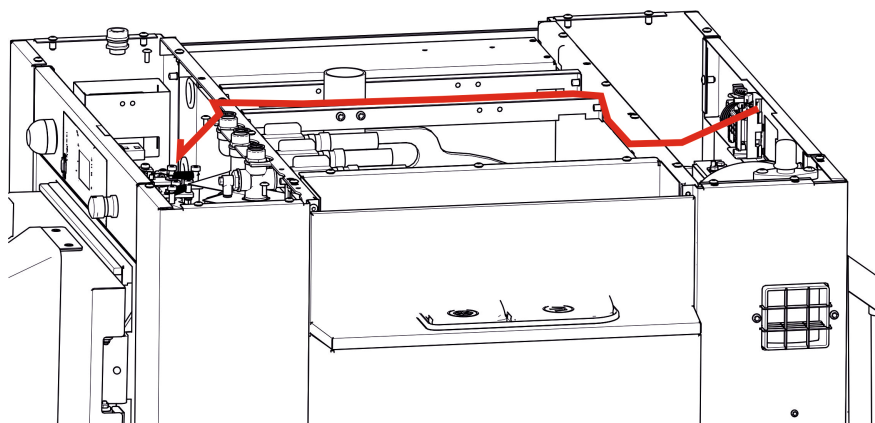

**STEP 4** : Connect the cable to the RS232 Port of Compass Pro (loading side)

**STEP 5** : Put back the upper casings,

**STEP 6** : Connect the connectivity board to the wire . Please follow the instruction **438907725**

**STEP 7** : Place the cover of the connectivity board.

Then, your washing machine is now connectable.

## 23 Function checks and settings at the first use.



### Caution



Before putting the machine into service, carry out the working tests.  
The operating inspection must be done by an approved technician.



### Caution



Check the settings into the Clarus Vibe settings section before putting the machine into service.



**Magnetic detector for tank door safety****Caution**

Before starting the appliance, please remove the bottom guard and check that the magnetic detector is correctly aligned.

For barrier machines, repeat this step on the second door.

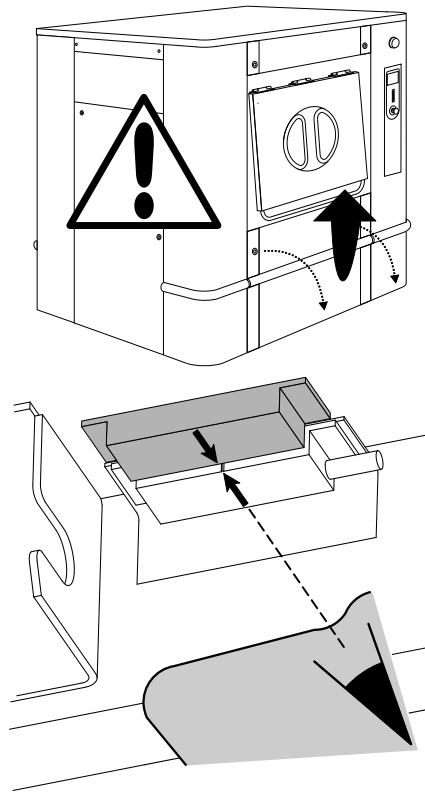
**Manual operation**

The procedure for operating the various machine functions manually is described in the chapter "Machine operation" under the heading "Manual operation".

- Switch on the machine's main switch and check the voltage on the three phases (3 x 400 volts).
- Check the direction of rotation of the **cage during spinning**. The inner drum should rotate as shown by the arrow on the drawing below. Check this point especially if you have changed the machine's motor or frequency converter.

Washer extractor barrier type :

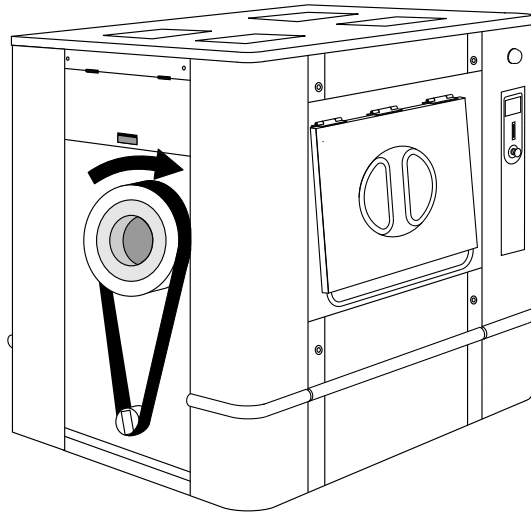

Washer extractor standard type (one door) :

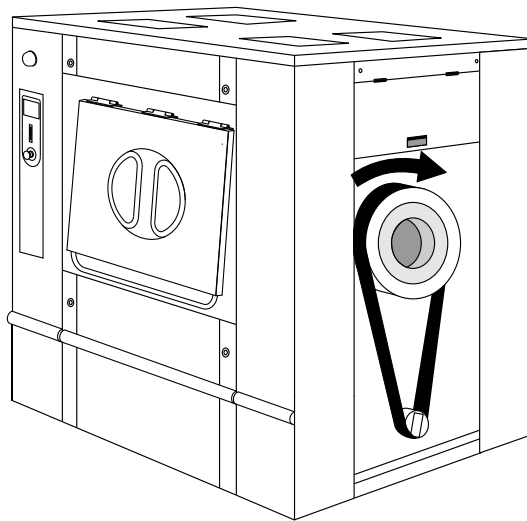

- Check the direction of rotation of motion motor fan . (see arrow stuck on the fan)  
Switch off the current and shift two phases on the main switch of the machine if the fan rotates in the wrong direction.
- Check that the inner drum is empty.
- Open the manual valves controlling the water and steam supplies (for steam heating machines).
- Operate the machine manually to fill with cold water, then hot water. Check that these water supplies are connected as they should be.
- Start the machine on wash action, and check that the motor is revolving alternately in the both ways, as normal for wash action.
- Start heating by programming a final temperature. Check that the steam valve opens or the heating element relay reacts, as appropriate.
- Check that the detergents container is working as they should.
- Check the water and steam connections and the drain valve for signs of any leakages.
- Empty the water from the machine and open its door.

#### Automatic operation

- Check that the external switch or switches are switched on and that the manual valves for water and steam (if the machine has steam heating) are open.
- Run one of the machine's built-in (standard) with heating.
- Check that the program proceeds normally, and the water filling, detergent filling, heating and motor action are all working in accordance with the program display on the display screen.

#### Final checking

If all function checks have been satisfactory, reassemble all protection casings.

**Settings at the first connection**

Before using the machine, you must set some settings like language, ... as shown below :

Screen 1/8 : Select language



Screen 2/8 : Select region



Screen 3/8 : Select segment



Screen 4/8 : Program layout setting



Screen 5/8 : Daylight saving

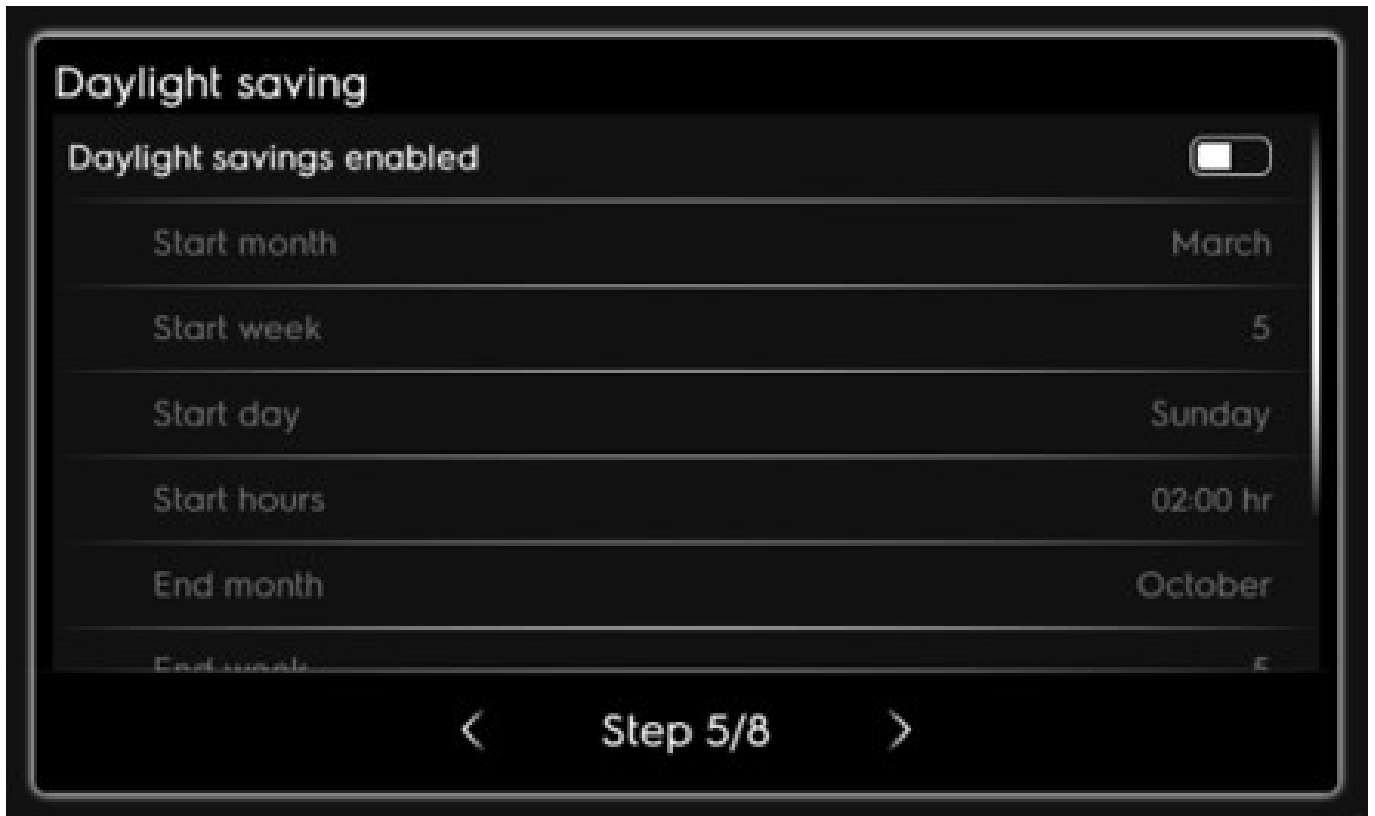

Screen 6/8 : Set date



Screen 7/8 : Set time



Screen 8/8 : Wizard complete to validate the previous settings.

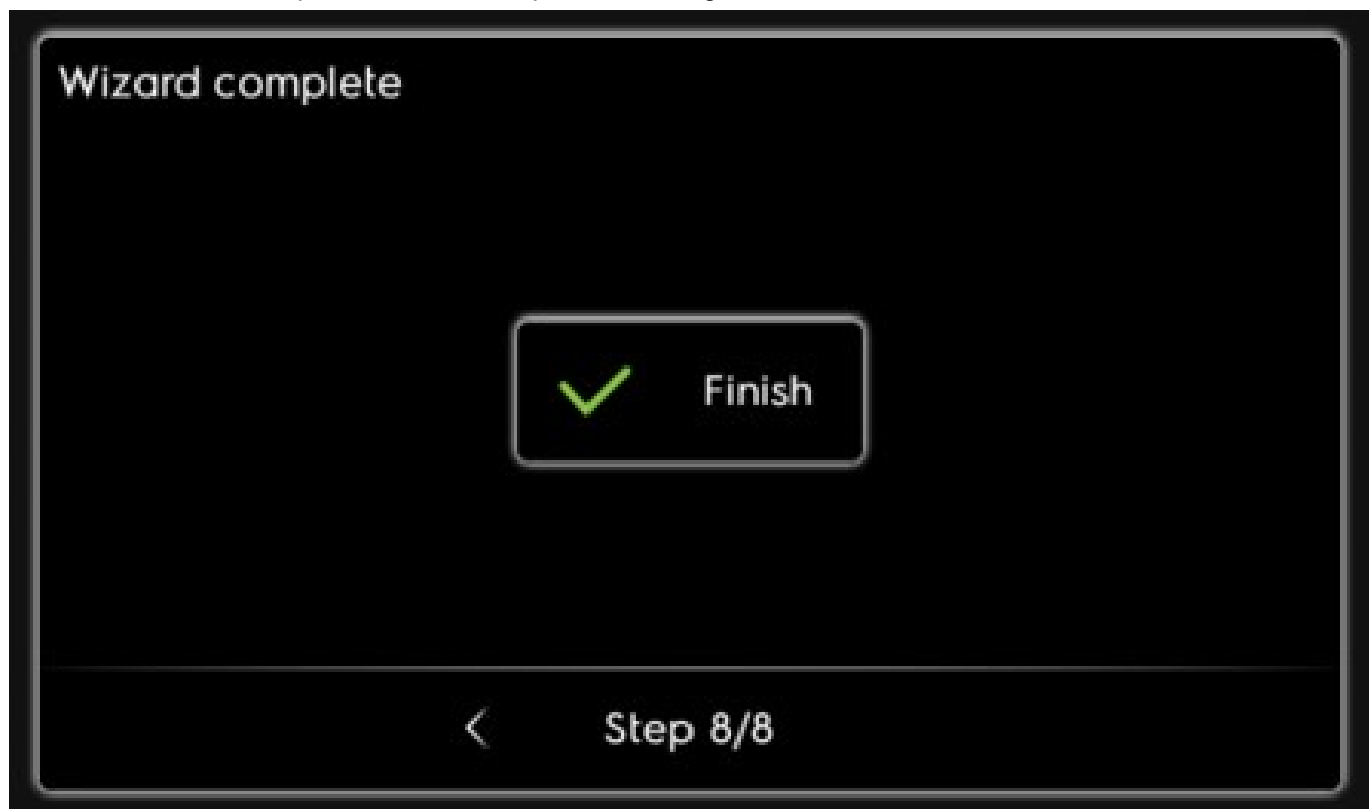















## 24 Explanation of washing symbols

(ISO 3758:2005 standard)

To overcome language barriers, the following are symbols used internationally to give you guidance and recommendations when washing different textiles.



### 24.1 Washing

The tub symbolizes washing.

Symbols	Max. washing temperature in °C ( °F)	Mechanical action
	95 (203)	normal
	95 (203)	mild
	70 (158)	normal
	60 (140)	normal
	60 (140)	mild
	50 (122)	normal
	50 (122)	mild
	40 (104)	normal
	40 (104)	mild
	40 (104)	very mild
	30 (86)	normal
	30 (86)	mild
	30 (86)	very mild
	40 (104)	wash by hand
	-	do not wash



### 24.2 Bleaching

The triangle symbolizes bleaching.

Symbols	Explanation
	Bleaching allowed (chlorine or oxygen).
	Bleaching allowed (only oxygen).
	Do not bleach.





### 24.3 Drying

The circle in a square symbolizes tumble drying.

Symbols	Explanation
	Can be put in a tumble dryer. Normal temperature.
	Can be put in a tumble dryer. Lower temperature.
	Do not put in a tumble dryer.



### 24.4 Ironing

The iron symbolizes the domestic ironing and pressing process.





Symbols	Explanation
	Max. temperature 200 °C.
	Max. temperature 150 °C.
	Max. temperature 110 °C. The steam can cause irreversible damages.
	Do not iron.

### 24.5 Dry or water cleaning

The circle symbolizes dry or water cleaning.

Symbols	Explanation
	Normal dry cleaning with perchloroethyl, solvent of hydrocarb.
	Mild dry cleaning with perchloroethyl, solvent of hydrocarb.
	Normal dry cleaning with solvent of hydrocarbon.



	<p>Mild dry cleaning with solvent of hydrocarbon.</p>
	<p>Do not dry clean.</p>
	<p>Normal water cleaning.</p>
	<p>Mild water cleaning.</p>
	<p>Very mild water cleaning.</p>

## 25 Conversion of measurement units

This following is a list of correspondences of the main frequency used units, to avoid the need to use measurement unit conversion table.

<b>bar</b>	1 bar = 100 000 Pa 1 bar = 1.019 7 kg/cm <sup>2</sup> 1 bar = 750.06 mm Hg 1 bar = 10 197 mm H <sub>2</sub> O 1 bar = 14.504 psi	<b>British thermal unit</b>	1 Btu = 1 055.06 J 1 Btu = 0.2521 kcal
<b>calorie</b>	1 cal = 4.185 5 J 1 cal = 10 <sup>-6</sup> th 1 kcal = 3.967 Btu 1 cal/h = 0.001 163 W 1 kcal/h = 1.163 W	<b>Continental horse power</b>	1 ch = 0.735 5 kW 1 ch = 0.987 0 HP
<b>cubic foot</b>	1 cu ft = 28 316 8 dm <sup>3</sup> 1 cu ft = 1 728 cu in	<b>cubic inch</b>	1 cu in = 16.387 1 dm <sup>3</sup>
<b>foot</b>	1 ft = 304.8 mm 1 ft = 12 in	<b>gallon (U.K.)</b>	1 gal = 4.545 96 dm <sup>3</sup> or l 1 gal = 277.41 cu in
<b>gallon (U.S.A.)</b>	1 gal = 3.785 33 dm <sup>3</sup> or l 1 gal = 231 cu in	<b>horse power</b>	1 HP = 0.745 7 kW 1 HP = 1.013 9 ch
<b>inch</b>	1 in = 25.4 mm	<b>joule</b>	1 J = 0.000 277 8 Wh 1 J = 0.238 92 cal
<b>kilogramme</b>	1 kg = 2.205 62 lb	<b>kg/cm<sup>2</sup></b>	1 kg/cm <sup>2</sup> = 98 066.5 Pa 1 kg/cm <sup>2</sup> = 0.980 665 bar 1 kg/cm <sup>2</sup> = 10 000 mm H <sub>2</sub> O 1 kg/cm <sup>2</sup> = 735.557 6 mm Hg
<b>pound</b>	1 lb = 453.592 37 g	<b>meter</b>	1 m = 1.093 61 yd 1 m = 3.280 83 ft 1 m = 39.37 in
<b>cubic meter</b>	1 m <sup>3</sup> = 1 000 dm <sup>3</sup> 1 m <sup>3</sup> = 35.214 7 cu ft 1 dm <sup>3</sup> = 61.024 cu in 1 dm <sup>3</sup> = 0.035 3 cu ft	<b>pascal</b>	1 Pa = 1 N/m <sup>2</sup> 1 Pa = 0.007 500 6 mm Hg 1 Pa = 0.101 97 mm H <sub>2</sub> O 1 Pa = 0.010 197 g/cm <sup>2</sup> 1 Pa = 0.000 145 psi 1 MPa = 10 bar
<b>psi</b>	1 psi = 0.068947 6 bar	<b>thermie</b>	1 th = 1 000 kcal 1 th = 10 <sup>+6</sup> cal 1 th = 4.185 5 x 10 <sup>+6</sup> J 1 th = 1.162 6 kWh 1 th = 3 967 Btu
<b>watt</b>	1 W = 1 J/s 1 W = 0.860 11 kcal/h	<b>watt-hour</b>	1 Wh = 3 600 J 1 kWh = 860 kcal
<b>yard</b>	1 yd = 0.914 4 m 1 yd = 3 ft 1 yd = 36 in	<b>temperature degrees</b>	0 °K = -273.16 °C 0 °C = 273.16 °K t °C = 5/9 (t °F - 32) t °F = 1.8 t °C + 32





Electrolux Professional AB  
341 80 Ljungby, Sweden  
[www.electroluxprofessional.com](http://www.electroluxprofessional.com)